

Montpellier

THE PERFECT BALANCE OF FUNCTION AND STYLE

LAUNDRY - DISHWASHING - COOKING - COOLING

Installation and Operating Instructions



Telescopic Cooker Hood

TCH261 / TCH291 - 60/90cm

Please read these instructions carefully before attempting to install or use this appliance.
We recommend that you keep these instructions in a safe place for future reference.

Welcome

Thank you for choosing this Montpellier Telescopic Cooker Hood.

Our Hoods have been designed to provide you with the best combination of style, reliability and performance to give you years of trouble-free use.

You may be familiar with a similar product, but please take time to read these instructions carefully before installing or using your Cooker Hood to ensure you get the most from your purchase.

We recommend that you keep this manual in a safe place for future reference.

Your Cooker Hood is covered by a comprehensive two year Parts & Labour Guarantee. In the unlikely event that you experience a problem with your Hood, you can rest assured that you are fully protected against the cost of repairs for the first 24 months. Please note that any claim must be accompanied by the model reference number, serial number and proof of purchase.

To activate your guarantee, you will need your product serial number. This can be found on the rear of the machine.

There are two ways to register your Guarantee:

- **Online:** Visit the Support page on our website and complete the online Product Registration form. www.montpellier-appliances.com
- **By Post:** Simply detach and fill in the form provided, attach a stamp and send it in the post. Don't forget to include your e-mail address so that we can send confirmation through to you.



Note: We are unable to take registrations over the phone.

2
YEAR
GUARANTEE
— PARTS & LABOUR —
ACROSS ALL OUR MODELS
Montpellier
www.montpellier-appliances.com

Important

The manufacturer cannot be held responsible for injuries or losses caused by incorrect use or installation of this product. Please note that the manufacturer reserves the right to invalidate the guarantee supplied with this product following incorrect installation or misuse of the appliance or use in a commercial environment.

This appliance is not designed to be used by people (including children) with reduced physical, sensorial or mental capacity, or who lack experience or knowledge about it, unless they have had supervision or instructions on how to use the appliance by someone who is responsible for their safety.

Under no circumstances should any external covers be removed for servicing or maintenance except by suitably qualified personnel.

Appliance information:

Please enter the details on the appliance rating plate below for reference, to assist Customer Care in the event of a fault with your appliance and to register your appliance for guarantee purposes.

Appliance Model _____

Serial Number _____

CE Declarations of Conformity:

This appliance has been manufactured to the strictest standards and complies with all applicable legislation, including Gas safety, Electrical safety (LVD) and Electromagnetic interference compatibility (EMC).

IMPORTANT INFORMATION FOR CORRECT DISPOSAL OF THE PRODUCT IN ACCORDANCE WITH EC DIRECTIVE 2002/96/EC.

At the end of its working life, the product must be taken to a special local authority waste collection centre or to a dealer providing appliance recycling services. Disposing of a household appliance separately avoids possible negative consequences for the environment and health. It also enables the constituent materials to be recovered, saving both energy and resources.

As a reminder of the need to dispose of household appliances separately, the product is marked with a crossed-out wheeled dustbin. 

Please note:

Under no circumstances should the extractor be connected to any gas ventilation system, flue system or hot air ducting system.

Do not vent the extractor into an attic or loft space.

Only house the extractor in rooms with adequate ventilation. Remember that the extractor is powerful and whatever air is extracted needs to be replaced.

Do not tile the extractor in. It should be removable for service or maintenance.

Do not use silicone sealant to secure the hood to the wall.

You must be able to isolate the extractor from the mains electrical supply after installation.

Steam cleaners must not be used when cleaning this appliance.

The performance of your extractor will vary depending on a number of factors. These include: type of extraction, length of ducting, room volume, ventilation available and cleanliness of the filters

Using your Extractor

For best performance, you should switch on the extractor 15 minutes before starting to cook and leave it to run for approximately 15 minutes after the end of cooking.

Control Panel

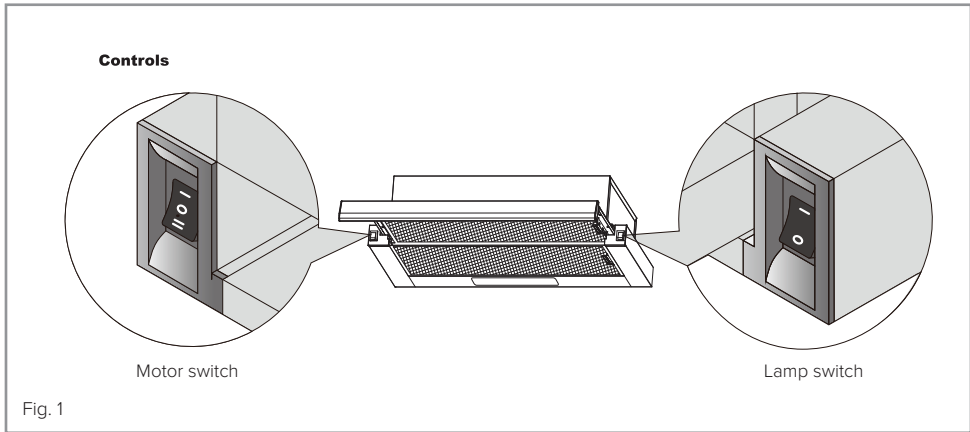

The telescopic canopy controls the electric power.
Pull out the telescopic panel to switch on the power; to switch power off, push the panel back in.
At either side of the panel are switches controlling the fan speed and the light.

- Light: switch button to "I" to illuminate the light.
switch button to "0" to turn it off.
- Speed: switch to "I" for low speed and "II" for high speed
"0" is the Off position.

Care and Maintenance

IMPORTANT : DO NOT PERFORM MAINTENANCE OR CLEANING OF THE EXTRACTOR WITHOUT FIRST SWITCHING OFF THE ELECTRICITY SUPPLY.

Cleaning

Use a non-abrasive cleaner. Any abrasive cleaner (including Cif) will scratch the surface and could erase the control panel markings.

You can clean your extractor effectively by simply using a dilute solution of water and mild detergent and drying to a shine with a clean cloth.

Cleaning the grease filter

The grease filter should be kept clean to minimise the risk of fire.

You should remove and clean the grease filter with hot soapy water at least once a month. You can also wash the grease filter in a dishwasher, ensuring that you place it in an upright position to prevent damage from other items in the dishwasher. After rinsing and drying, replace the filter.

To remove the grease filter, push in the button on the handle and then pull down on the filter at the front. When you have released it at the front, pull out the filter. To replace the grease filter, repeat the above steps in reverse.

Please note:

Cleaning the grease filter in the dishwasher may lead to discolouration. This is normal and does not constitute a fault with the appliance.

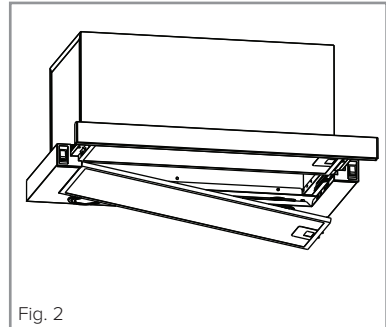

Fig. 2

Changing the Light

NOTE: Replacement of the LED lamp must be carried out by a qualified electrician.

IMPORTANT: DO NOT PERFORM MAINTENANCE OR CLEANING OF THE EXTRACTOR WITHOUT FIRST SWITCHING OFF THE ELECTRICITY SUPPLY.

1. According fig.4-I take down grease filters.
2. According fig.4-II take down LED lamp.
3. According fig.4-III,install new LED lamp.
4. Installation grease filters.

TCH261 / TCH291

1x4W MAX

The light is designed for use during cooking and not for general room illumination. Extended use of the light can reduce its life span. Please contact your local retailer in order to purchase a new LED lamp when replacing a damaged or a faulty one.

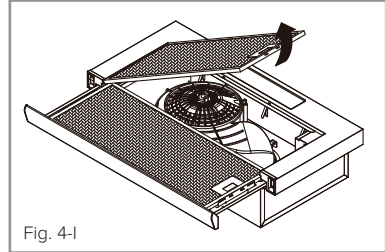

Fig. 4-I

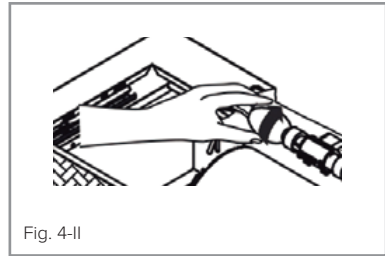

Fig. 4-II

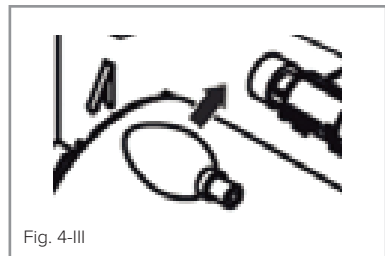

Fig. 4-III

PROTECTION LINE

5A Fuse is installed inside the plug to protection line.

Electrical Information

Mains electrical voltage: 230 – 240Vac, 50Hz

Total rated power consumption:

44W

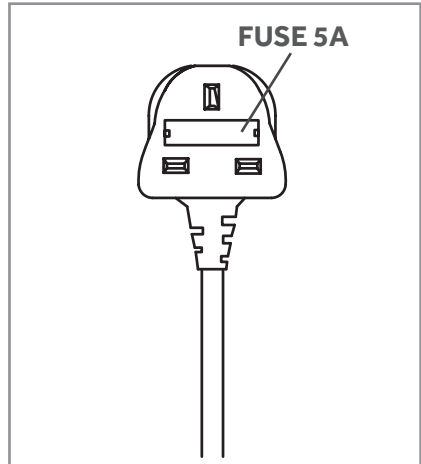

Troubleshooting

If your extractor is not working:

1. Check that the mains supply has not been switched off.
2. Check that the fuse in the spur has not blown.

GUARANTEE

Your new product is guaranteed against defects in materials and/or workmanship. Any parts found to be defective will be repaired or replaced at our discretion. All repairs must be carried out by an authorised service engineer.

THIS GUARANTEE IS VALID PROVIDING THAT :

- The appliance has been installed by a suitably qualified person
- Installation has been carried out in accordance with instructions and current legislation
- Proof of purchase can be produced
- The appliance has been used for domestic purposes only
- The appliance has not been tampered with or repair attempted or modified by any unauthorised person

THIS GUARANTEE DOES NOT COVER :

- Damage by misuse, neglect or transit
- Use of parts that have not been recommended
- Routine maintenance, general wear & tear and installation faults
- Rubber seals, removable glass and/or plastic parts, fuses or light bulbs which all need replacing periodically
- Second-hand or reconditioned appliances
- Appliances used for commercial or professional purposes

This guarantee does not in any way affect your statutory legal rights.

Mounting your Extractor

Information

Ensure the power has been turned off before beginning this installation.

Before installing the cooker hood, please first fix the damper flap on the air outlet of the hoods.

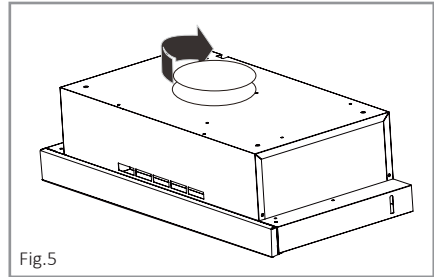

Fig.5

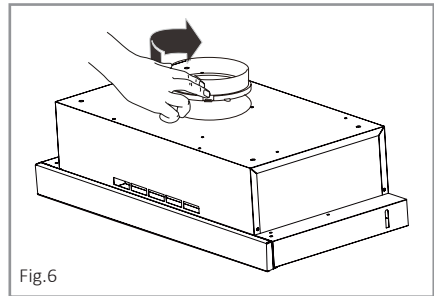

Fig.6

Decorative strip installation

As shown in Figure 7, fix the wide retainer plate (16mm) to the machine with 2 screws.

At this time, the extension length of the fixing plate should be 10mm, and the two screws pass through the sliding plate long hole and fixed on the fixing plate, adjust the sliding plate to the proper position, and tighten the screw nail. This state decorative panel extends from 10mm to 24mm.

As shown in Figure 8, fix the etainer plate narrow side (10mm) to the machine with 2 screws.

At this time, the extension length of the fixing plate should be 16mm, and the two screws pass through the sliding plate long hole and fixed on the fixing plate, adjust the sliding plate to the proper position, and tighten the screw nail. This state decorative panel extends from 16mm to 30mm.

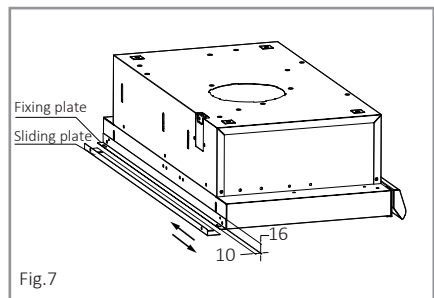

Fig.7

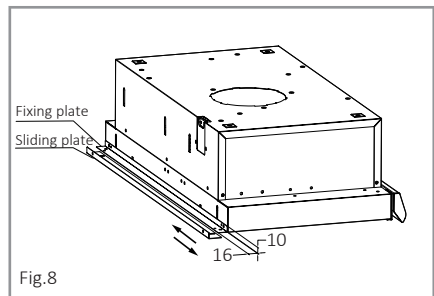

Fig.8

Mounting your Extractor

Information

When cutting or drilling into wall or ceiling, do not damage electrical wiring or other hidden utilities.

Fix the position of the hood according to Fig.7 above. Then use the stencil to drill out 4 holes in the cabinet. Insert rawl plugs and screws to correspond with the 4 holes.

The distance between the bottom of the hood and the cabinet on either side should be less than 2mm. Ensure that there is no gap between the top of the hood and the cabinet.

The gap at the back should be no more than 10mm and the plug must be accessible.

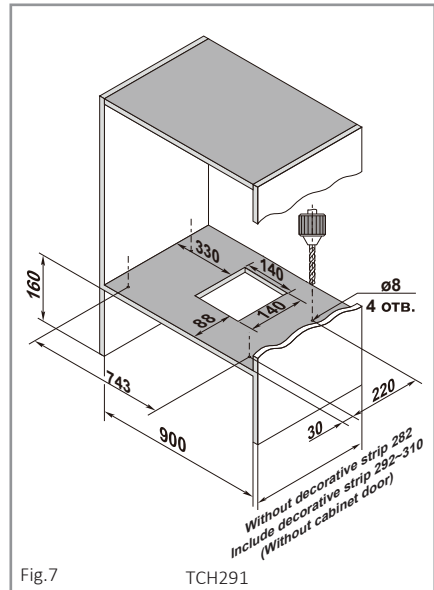
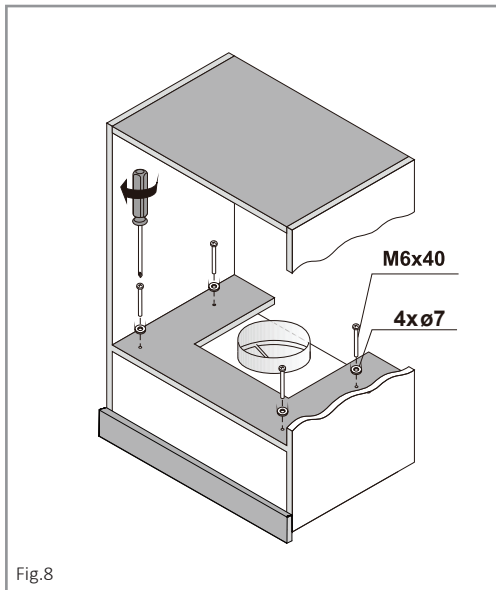
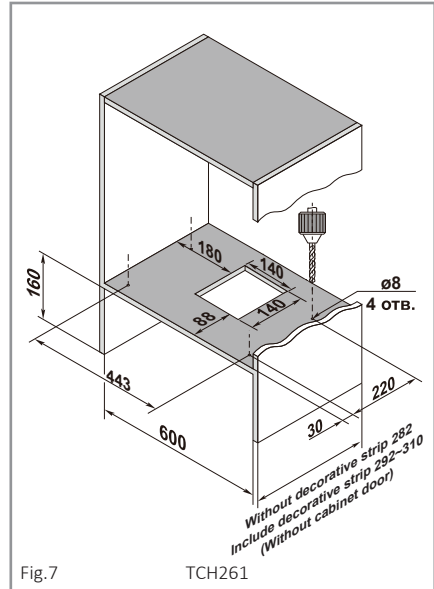

Mounting your Extractor

The cooker hood can be vented in different ways according to requirements:

Connect the hose (not supplied) with the air duct (Fig.8).

Vertical is the most common. If your kitchen has an attic space above, the ducting may be run up through the cupboard and attic to the roof (Fig.9).

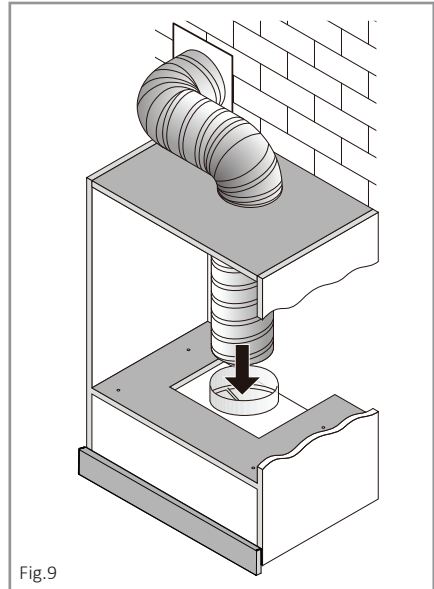

Fig.9

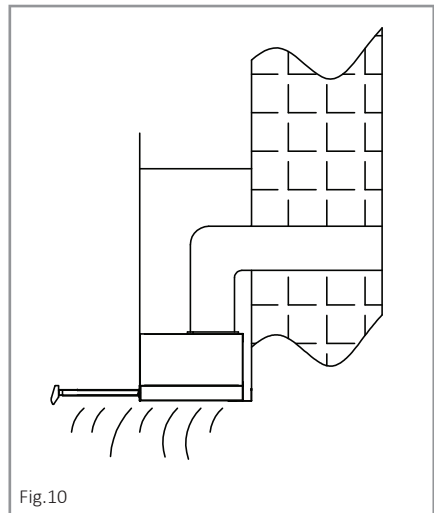

Fig.10

Energy Efficiency Information

Attribute	Symbol	Value	Units
Model Identification		TCH261 / TCH291	
Annual Energy Consumption	AEC_{Hood}	26.7	kWh
Time Increase factor	f	1.7	
Fluid Dynamic Efficiency	FDE_{Hood}	8.2	
Energy Efficiency Index	EEl_{Hood}	69.2	
Measured Airflow at Best Efficiency Point	Q_{BEP}	92.5	m ³ /h
Measured Pressure at Best Efficiency Point	P_{BEP}	123	Pa
Maximum Airflow	Q_{MAX}	200.5	m ³ /h
Measured Electric Power at Best Efficiency Point	W_{BEP}	38.4	W
Nominal Lighting Power	WL	4.0	W
Average Illumination of the lighting system on the cooking surface	E_{Middle}	91	Lux
Measured Power Consumption in standby	P_s	---	W
Measured Power Consumption off mode	P_o	0.0	W
Noise level	L_{WA}	61	dBA
Grease Filter Efficiency	GFE_{Hood}	45.4(F)	%
Lamp Efficiency	LE_{Hood}	23(B)	%

E & O E. All instructions, dimensions and illustrations are provided for guidance only. MONTPELLIER reserve the right to change specifications without prior notice.

Here For You

After-sales assistance

If you continue to experience problems with your Telescopic Hood, please call the Montpellier customer service helpline on: **03333 234 473**

Please have all your product details available, including the model number, serial number, date of purchase, and your retailer's details before registering a fault.

The service call cannot progress without this information.

Your 2 year Manufacturer's guarantee

THIS DOES NOT AFFECT YOUR STATUTORY RIGHTS.

Your new Montpellier appliance carries a free guarantee which protects you against the cost of repairs during the first 24 months from date of purchase provided that:

Any claim is accompanied by evidence of the model reference, model serial number and proof of purchase, such as a Sales Receipt, showing that the appliance was purchased within the 24 months prior to the date of claim.

What is not covered under the Guarantee

- Any appliance not correctly installed and operated in accordance with the manufacturer's instructions.
- Any appliance that is used for anything other than domestic purposes.
- Any defect caused by accident, misuse, unauthorised modification or inexpert repair.
- Cost of Call-out where a fault cannot be found with the appliance.
- Cost of Call-out for work covering routine maintenance, such as, but not exclusively, cleaning of filters or defrosting.
- Cost of Call-out for work required to correct the alignment of doors following door reversal procedures carried out by you.
- Use of the appliance by anyone other than the Householder.
- Use in any commercial environment.
- Consumable items, such as, but not exclusively, fuses in plugs, bulbs and breakable items which require routine replacement.
- Repair costs incurred that have not been authorised by Montpellier service and/or carried out by a non-approved Montpellier engineer.
- Montpellier Appliances do not accept claims for consequential loss, rusting, corroding, delivery damage or scratches.

YOUR GUARANTEE IS VALID ONLY IN THE UK.

To register your appliance simply complete the card in your appliance pack and return it with a stamp affixed or alternatively you can register online at **www.montpellier-appliances.com/support**

SERVICE HELP-LINE

Should your appliance develop a fault, please call the Montpellier customer service helpline on:

03333 234 473

Please remember to have all your product details available, including the model number, serial number, date of purchase and your retailer's details before registering a fault.....

Montpellier Domestic Appliances Ltd.

Unit 1, Tewkesbury Retail Park, Northway Lane,
Tewkesbury, Gloucestershire GL20 8JU

www.montpellier-appliances.com



The symbol on the product or on its packaging indicates that this product may not be treated as household waste. Instead it shall be handed over to the applicable collection point for the recycling of electrical and electronic equipment. By ensuring this product is disposed of correctly, you will help prevent potential negative consequences for the environment and human health, which could otherwise be caused by inappropriate waste handling of this product. For more detailed information about recycling of this product, please contact your local city office, your household waste disposal service or the shop where you purchased the product.