

Montpellier

THE PERFECT BALANCE OF FUNCTION AND STYLE

LAUNDRY - DISHWASHING - COOKING - COOLING

Installation and Operating Instructions



Integrated 17ltr Solo Microwave

MWBI17-300 - Stainless Steel - 300mm Deep

Please read these instructions carefully before attempting to install or use this appliance.
We recommend that you keep these instructions in a safe place for future reference.

Welcome

Thank you for choosing this Montpellier Integrated Microwave.

Our Microwaves have been designed to provide you with the best combination of style, reliability and performance to give you years of trouble-free use.

You may be familiar with a similar product, but please take time to read these instructions carefully before installing or using your Integrated Microwave to ensure you get the most from your purchase.

We recommend that you keep this manual in a safe place for future reference.

Your Integrated Microwave is covered by a comprehensive two year Parts & Labour Guarantee. In the unlikely event that you experience a problem with your Microwave, you can rest assured that you are fully protected against the cost of repairs for the first 24 months. Please note that any claim must be accompanied by the model reference number, serial number and proof of purchase.

To activate your guarantee, you will need your product serial number. This can be found on the rear of the machine.

There are two ways to register your Guarantee:

- **Online:** Visit the Support page on our website and complete the online Product Registration form. www.montpellier-appliances.com
- **By Post:** Simply detach and fill in the form provided, attach a stamp and send it in the post. Don't forget to include your e-mail address so that we can send confirmation through to you.



Note: We are unable to take registrations over the phone.

2
YEAR
GUARANTEE
— PARTS & LABOUR —
ACROSS ALL OUR MODELS
Montpellier
www.montpellier-appliances.com

Description Of The Appliance



1. Door & Viewing Window
2. LED Display Panel
3. Control Panel
4. Push Button Door Control

(Picture indicative of model supplied)

CONTENTS:

Section 1. Installation

Section 2. Safety Advice

Section 3. Operating the Appliance

Section 4. Maintenance

Section 1. Installation

- Remove all packaging, protective film and securing tape from the appliance.
- Wash the interior of the appliance with warm soapy water.
- Position the appliance in a dry atmosphere.
- Keep the microwave oven away from the TV, Radio or antenna as picture disturbance or noise may occur.
- Please note that certain parts of this appliance have been protected with a light film of oil. During initial use you may see light smoke coming from the oven as the oil is burnt off. This is quite normal.
- Connect the plug to an adjacent 'easily accessible' 13amp socket outlet and ensure that the appliance is not standing on the supply cable.
- Never operate this oven without food or liquids inside
- Remove the turntable and rotating ring from the packaging, wash in warm soapy water and dry thoroughly. Fit the rotating ring on the base of the interior and then carefully place the turntable onto the rotating drive, ensuring that it 'locks' into place.
- The turntable and rotating ring can be removed from the appliance and washed using warm soapy water
- Replace the rotating ring on the base of the interior and then carefully place the turntable onto the rotating drive, ensuring that it 'locks' into place
- This appliance is fitted with a safety door interlock. Do not operate the appliance if either of the two interlock levers are damaged. Please note that the appliance will fail to operate if the door has not been closed correctly.
- The turntable rotates whilst the appliance is operating – this helps the food/liquids to cook/heat more evenly.

To install this appliance, please proceed as follows:

- The plug fitted to this appliance must be connected to an adjacent 13amp plug socket.
- If the socket is located behind the appliance and no longer accessible to the consumer, you must ensure that the consumer can turn off the appliance via an accessible switched spur socket.
- You must ensure that the cable is not trapped beneath the appliance.
- If the power supply cord is damaged, it must be replaced by the manufacturer, it's service agent or similarly qualified persons in order to avoid a hazard.

A. Built-in Furniture

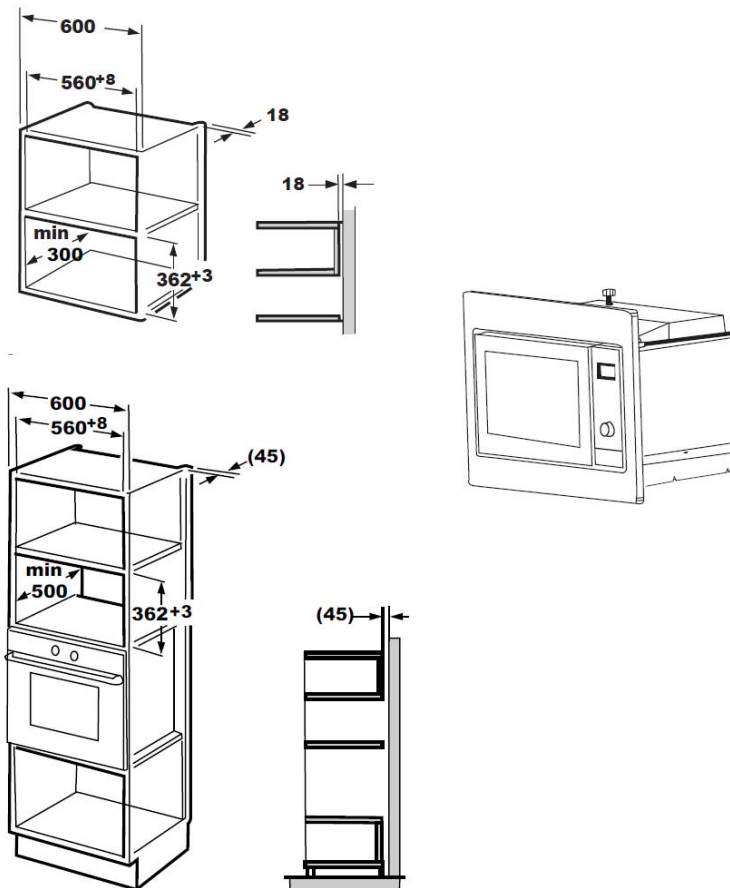

B. Install the Oven

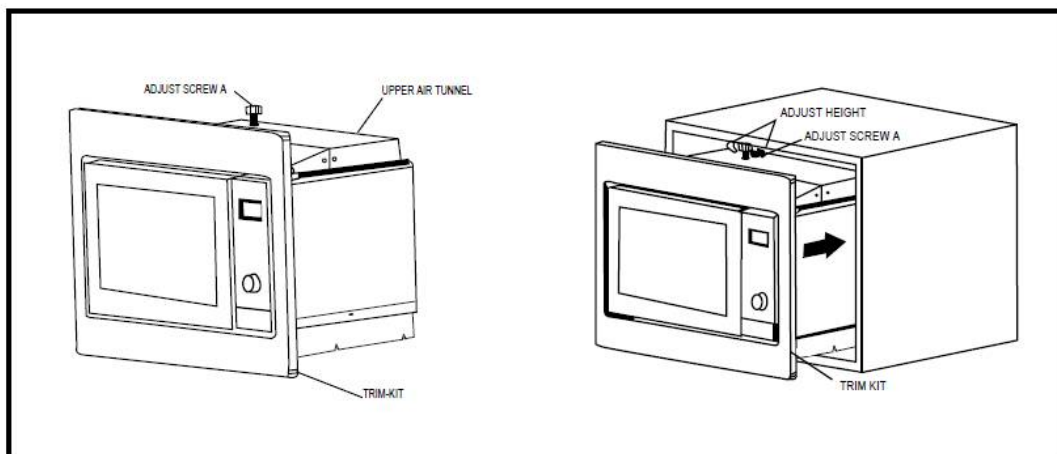

1. Fix ADJSUTSCREW A on the UPPER AIR TUNNEL of the oven, and then install the oven into the cabinet.

- Adjust the height of ADJUST SCREW A to keep 1mm gap between the ADJUST SCREW A and the top plane of cabinet.
- Do not trap or kink the power cord.
- Make sure that the oven is installed in the center of the cabinet.

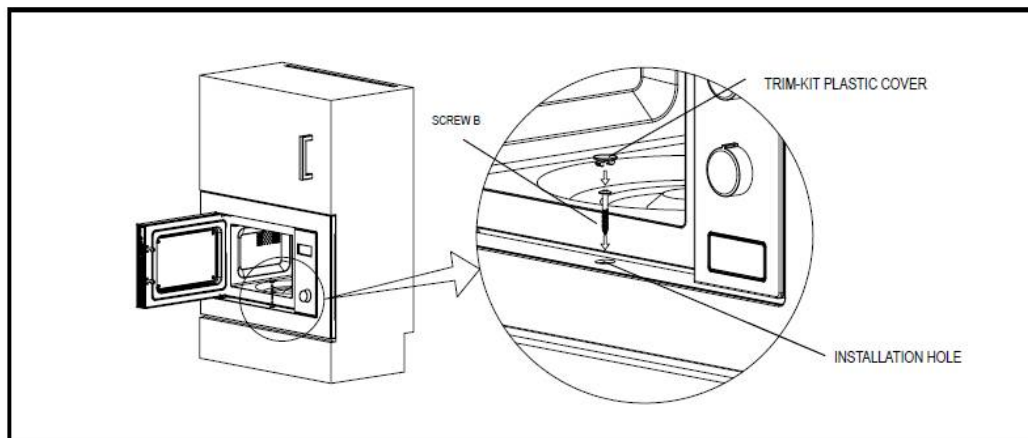

2. Open the door; fix the oven to the cabinet with SCREW B at the INSTALLATION HOLE of TRIM KIT. Then fix the TRIM-KIT PLASTIC COVER to the INSTALLATION HOLE.

Section 2. Safety Advice

- Please read this booklet thoroughly before installing and switching on the appliance. The manufacturer accepts no responsibility for incorrect installation and usage.
- This appliance is guaranteed for Domestic Use Only.
- The appliance shall not be used by children aged from 8 years and above and persons with reduced physical, sensory or mental capabilities, or lack of experience and knowledge, unless they have been given supervision or instruction on how to use the appliance in a safe way and understand the hazards involved. Children shall not play with the appliance. Cleaning and user maintenance shall not be made by children without supervision.
- This appliance must only be used for cooking/heating foods and liquids. Do not use it for any other purpose.
- If using an adaptor, this must be used in accordance with the manufacturers instructions and ensure that the electrical circuit is not overloaded as this could cause overheating.
- Do not twist or bend the cables, and keep them away from hot surfaces.
- If the power supply cord is damaged, it must be replaced by the manufacturer, it's service agent or similarly qualified persons in order to avoid a hazard.
- Do not plug in or unplug this appliance with wet hands.
- Following installation make sure that the power cable is not trapped underneath the appliance.
- Remove all twist-ties from food bags before placing them in the oven.
- Do not heat oil or fat inside the oven.
- Do not over cook food inside the oven.
- Do not heat sealed containers or try to cook eggs (inside their shells) in this oven – they may explode.
- Potatoes, sausages and items such as chestnuts must be peeled or pierced before placing them in the oven.
- After liquids have been heated in the oven wait a few moments before removing the container – handle with care as the container may be hot – use protective gloves.

- Liquids and foods should be stirred and the temperature checked prior to consumption.
- If you cover a container with cling film, remove it very carefully after the cooking process has finished – steam will escape and may burn your hands.
- Always let the turntable cool down before washing it.
- Never cook foods directly on the turntable.
- Make sure that plates/dishes do not touch the walls when the turntable rotates.
- Keep the interior surfaces clean. Failure to do this could lead to the appliance malfunctioning.

Important Utensil Information

- Do not use metal pans or dishes with metal handles.
- Do not use anything with a metal trim.
- Do not use paper covered wire twist-ties on plastic bags.
- Do not use melamine dishes as they contain a material which will absorb microwave energy. This may cause the dishes to crack or burn, and will slow down the cooking speed.
- Use only cookware that is approved to be used in a microwave oven.
- Do not cook using a container with a restricted opening, such as bottles, as they may explode.
- Do not heat baby bottles with the teat left on and remove the teat if replacing the bottle back into the oven.
- Only use thermometers that are approved for microwave ovens.
- Do not use the microwave oven for heating utensils.

Section 3. Operating the Appliance

3.1. Setting The Clock

Press the Kitchen Timer/Clock button twice, the hours will flash in the LED panel Turn the Rotary knob to select the correct hour

Press the Kitchen Timer/Clock button, the minutes will flash in the LED panel Turn the Rotary knob to select the correct minutes

Press the Kitchen Timer/Clock button to confirm the new time setting.

3.2. Microwave Cooking

Press the Microwave button, the LED will display P100 Press the same button several times to select either P80, P50, P30 or P10. (You can also use the Rotary knob to do this).

Press the Start button and then use the Rotary knob to select the required cooking time

Press the Start button again to begin cooking.

Press Stop/Clear at any time to end or cancel the cooking time

Please note the following power levels:

P100 = 100%

P80 = 80%

P50 = 50%

P30 = 30%

P10 = 10%

3.3. Kitchen Timer

Press the Kitchen Timer button, the LED will display 0:00

Turn the Rotary knob to select the required time

Press the Start button to confirm and start

When the set time has elapsed a buzzer will sound for 5 seconds

N.B. the maximum time you can set is 95 minutes

3.4. Quick Start

Press the Start button to immediately start cooking at 100% power for a period of 30 seconds

Each added press of the Start button will increase the cook time by 30 seconds

Press Stop/Clear at any time to end or cancel the cooking time

3.5. Defrost by Weight

Press the Weight/Defrost button once and the LED will display 'dEF1'

Turn the Rotary knob to select the weight of the food to be defrosted

Press the Start button to start defrosting

N.B. The range of weight that can be selected is between 100 to 2000g

Press Stop/Clear at any time to end or cancel the defrosting It is your responsibility to ensure that food is defrosted correctly!

3.7. Defrost by Time

Press the Weight/Defrost button twice and the LED will display 'dEF2' Turn the Rotary knob to select the defrost time
Press the Start button to start defrosting
Press Stop/Clear at any time to end or cancel the defrosting It is your responsibility to ensure that food is defrosted correctly!
N.B. Defrost power is always P30, you cannot change this!

3.8. Auto Menu

Turn the Rotary knob to select the required menu, A1 to A8
Press the Start button to confirm the required menu
Turn the Rotary knob to select the default weight shown in the chart below
Press the Start button to start cooking
Press Stop/Clear at any time to end or cancel the selected menu

Menu	Weight	Display
A-1 Pizza	200 g	200
	400 g	400
A-2 Meat	250 g	250
	350 g	350
	450 g	450
A-3 Vegetable	200 g	200
	300 g	300
	400 g	400
A-4 Pasta	50g(with 450 ml cold water)	50
	100g(with 800 ml cold water)	100
A-5 Potato	200 g	200
	400 g	400
	600 g	600
A-6 Fish	250 g	250
	350 g	350
	450 g	450
A-7 Beverage	1 cup(120 ml)	1
	2 cups(240 ml)	2
	3 cups(360ml)	3
A-8 Popcorn	50 g	50
	100 g	100

3.9. Child Lock Function

To lock, press and hold Stop/Clear for 3 seconds or until you hear a long audible 'beep'. A key sign will be displayed in the LED panel.

To unlock, simply repeat the above procedure.

3.10. Suitable Materials/Utensils

Aluminum foil	Shielding only. Small smooth pieces can be used to cover thin parts of meat or poultry to prevent overcooking. Arcing can occur if foil is too close to oven walls. The foil should be at least 1 inch (2.5cm) away from oven walls.
Browning dish	Follow manufacturer's instructions. The bottom of browning dish must be at least 3/16 inch (5mm) above the turntable. Incorrect usage may cause the turntable to break.
Dinnerware	Microwave-safe only. Follow manufacturer's instructions. Do not use cracked or chipped dishes.
Glass jars	Always remove lid. Use only to heat food until just warm. Most glass jars are not heat resistant and may break.
Glassware	Heat-resistant oven glassware only. Make sure there is no metallic trim. Do not use cracked or chipped dishes.
Oven cooking bags	Follow manufacturer's instructions. Do not close with metal tie. Make slits to allow steam to escape.
Paper plates and cups	Use for short-term cooking/warming only. Do not leave oven unattended while cooking.
Paper towels	Use to cover food for reheating and absorbing fat. Use with supervision for a short-term cooking only.
Parchment paper	Use as a cover to prevent splattering or a wrap for steaming.
Plastic	Microwave-safe only. Follow the manufacturer's instructions. Should be labeled "Microwave Safe". Some plastic containers soften, as the food inside gets hot. "Boiling bags" and tightly closed plastic bags should be slit, pierced or vented as directed by package.
Plastic wrap	Microwave-safe only. Use to cover food during cooking to retain moisture. Do not allow plastic wrap to touch food.
Thermometers	Microwave-safe only (meat and candy thermometers).
Wax paper	Use as a cover to prevent splattering and retain moisture.

3.11. Unsuitable Materials/Utensils

Aluminum tray	May cause arcing. Transfer food into microwave-safe dish.
Food carton with metal handle	May cause arcing. Transfer food into microwave-safe dish.
Metal or metal-trimmed utensils	Metal shields the food from microwave energy. Metal trim may cause arcing.
Metal twist ties	May cause arcing and could cause a fire in the oven.
Paper bags	May cause a fire in the oven.
Plastic foam	Plastic foam may melt or contaminate the liquid inside when exposed to high temperature.
Wood	Wood will dry out when used in the microwave oven and may split or crack.

3.12. Cooking Tips

- a) Place thicker areas of food towards the outer area of the turntable and thinner food towards the centre
- b) Always follow the cooking instructions on the food packaging
- c) Turn or stir food during the cooking to ensure even cooking
- d) Allow the cooked food to 'stand' for a while before consuming
- e) If you use a 'browning' dish, stand it on a plate in the oven
- f) Do not let plastic 'cling film' to come in contact with the food during the cooking process

3.13. Normal Operating Points to Note

You will hear the sound of the motor during operation – this is quite normal.

There will be an audible 'buzzer/beep' at the end of the cooking period.

You may hear the turntable rotating inside the oven, this is normal.

You may see water on the inside of the door – this is quite normal due to condensation forming from some foods and/or liquids during the cooking process.

The microwave oven light may appear dim at times – this may happen during the cooking process and is quite normal, particularly during low power cooking.

Section 4. Maintenance

Before any maintenance or cleaning work is carried out, **DISCONNECT** the appliance from the **ELECTRICITY** supply and ensure that the appliance is completely cool.

4.1. Internal Cleaning

Clean the interior and accessories with warm soapy water. Rinse and dry thoroughly. Do not use detergents, abrasive powders, highly perfumed cleaning products, wax polishes or cleaning products containing bleach or alcohol.

4.2. External Cleaning

Wash the fascia and door with warm soapy water. Do NOT use abrasive products.

4.3. What to do if something goes wrong

There is no power to the appliance:

- Check there is not a power cut
- Check there is power to the electric socket/appliance
- Check the fuse in the plug (Must be 13 amp)

The oven will not operate:

- Is the Timer control set to the required time?
- Has the door been closed correctly?

Here For You

After-sales assistance

If you continue to experience problems with your Integrated Microwave, please call the Montpellier customer service helpline on: **03333 234473**

Please have all your product details available, including the model number, serial number, date of purchase, and your retailer's details before registering a fault.

The service call cannot progress without this information.

Your 2 year Manufacturer's guarantee

THIS DOES NOT AFFECT YOUR STATUTORY RIGHTS.

Your new Montpellier appliance carries a free guarantee which protects you against the cost of repairs during the first 24 months from date of purchase provided that:

Any claim is accompanied by evidence of the model reference, model serial number and proof of purchase, such as a Sales Receipt, showing that the appliance was purchased within the 24 months prior to the date of claim.

What is not covered under the Guarantee

- Any appliance not correctly installed and operated in accordance with the manufacturer's instructions.
- Any appliance that is used for anything other than domestic purposes.
- Any defect caused by accident, misuse, unauthorised modification or inexpert repair.
- Cost of Call-out where a fault cannot be found with the appliance.
- Cost of Call-out for work covering routine maintenance, such as, but not exclusively, cleaning of filters or defrosting.
- Cost of Call-out for work required to correct the alignment of doors following door reversal procedures carried out by you.
- Use of the appliance by anyone other than the Householder.
- Use in any commercial environment.
- Consumable items, such as, but not exclusively, fuses in plugs, bulbs and breakable items which require routine replacement.
- Repair costs incurred that have not been authorised by Montpellier service and/or carried out by a non-approved Montpellier engineer.
- Montpellier Appliances do not accept claims for consequential loss, rusting, corroding, delivery damage or scratches.

YOUR GUARANTEE IS VALID ONLY IN THE UK.

To register your appliance simply complete the card in your appliance pack and return it with a stamp affixed or alternatively you can register online at **www.montpellier-appliances.com/support**

SERVICE HELP-LINE

Should your appliance develop a fault, please call the Montpellier customer service helpline on: **03333 234473**

Please remember to have all your product details available, including the model number, serial number, date of purchase and your retailer's details before registering a fault.

Montpellier Domestic Appliances Ltd.

Unit 1, Tewkesbury Retail Park, Northway Lane,
Tewkesbury, Gloucestershire GL20 8UY

www.montpellier-appliances.com



The symbol on the product or on its packaging indicates that this product may not be treated as household waste. Instead it shall be handed over to the applicable collection point for the recycling of electrical and electronic equipment. By ensuring this product is disposed of correctly, you will help prevent potential negative consequences for the environment and human health, which could otherwise be caused by inappropriate waste handling of this product. For more detailed information about recycling of this product, please contact your local city office, your household waste disposal service or the shop where you purchased the product.