

**Series 4, Heat pump tumble dryer, 8 kg
WTH85224GB**



**The dryer for especially efficient drying:
energy efficiency class A++.**

- **Easy Clean Filter:** efficient drying with easy maintenance.
- **Auto Dry:** Automatically senses when your load is dried.
- **Super Quick 40:** Fast drying for smaller loads
- **Sensitive Drying System:** for gentle drying without creases.
- **Anti Vibration Design:** extremely stable and quiet thanks to special vibration protection.

Technical Data

Removable top:	No
Built-in / Free-standing:	Freestanding
Door hinge:	Right
Length electrical supply cord:	180 cm
Dimensions:	842x598x613 mm
Net weight:	48.4 kg
Fluorinated greenhouse gases:	R290
Hermetically sealed equipment:	Yes
EAN code:	4242005469789
Connection rating:	600 W
Fuse protection:	10 A
Voltage:	220-240 V
Frequency:	50 Hz
Loading capacity:	8.0 kg
Energy efficiency rating:	A++
Energy consumption electric dryer, full load - NEW (2010/30/EC):	1.74 kWh
Energy consumption electric dryer, partial load - NEW (2010/30/EC):	1.02 kWh
Condensation efficiency class - NEW (2010/30/EC):	A
Average condensation efficiency full load (%):	83 %
Average condensation efficiency partial load (%):	83 %

Optional accessories

- WTZ27400 Stacking kit with pull-out shelf
WTZ27410 Stacking kit



Series 4, Heat pump tumble dryer, 8 kg WTH85224GB

**The dryer for especially efficient drying:
energy efficiency class A++.**

Performance

- Energy²: 119 kWh

Programmes/functions

- Standard programmes: cotton, easy care
- Special programmes: Woollens, Mixed Load, Towels, Timed programme warm, Timed programme cold, Sportswear, Super Quick 40, Shirts/blouses

Key features

- Touch control buttons: Low heat, Reduced ironing, Drying length, fine-tuning for drying level, 24 h, end Time Delay

Additional features

- EasyClean filter
- Fully electronic control dial for sensor programmes and timed programmes
- Fully electronic control dial for sensor drying, including timed and special programmes
- LED Display for remaining time and 24 hours time delay, programme status indication, special functions
- Sensitive drying: large stainless steel drum with textile care and revolution drying system
- AntiVibration design: for greater stability and quietness
- No
- Container for condensed water
- Full container tank indicator
- Warning for fluff filter and condensed water container
- no
- Child lock
- Anti-crease cycle at the end of the programme
- Buzzer to indicate the end of cycle
- NewValue door with cover glass, silver-white
- pull-open latch
- Door hinge: right-hand
- Metal door catch

Technical Information

- slide-under installation
- Dimensions (H x W): 84.2 cm x 59.8 cm
- Appliance depth: 61.3 cm
- Appliance depth incl. door: 64.8 cm
- Appliance depth with open door: 109.6 cm

**Series 4, Heat pump tumble dryer, 8
kg
WTH85224GB**

Measurements in mm

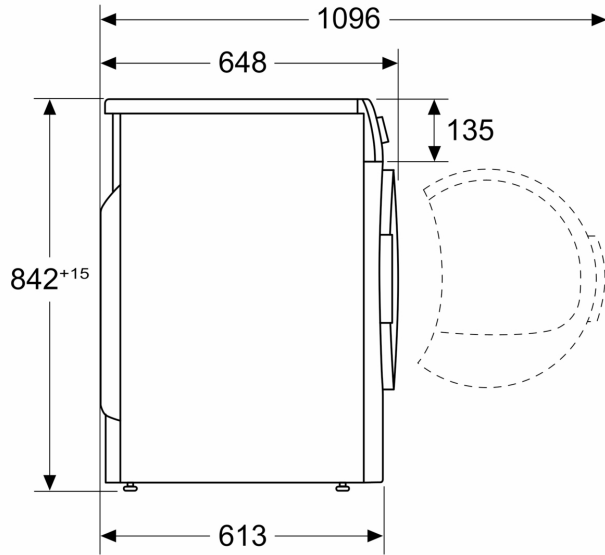

Measurements in mm

