

Series 6, Washing machine, front loader, 10 kg, max. 1400 rpm WGG254F0GB



Perfect results with minimum detergent and water consumption thanks to i-DOS automatic dosing and ActiveWater Plus.

- **A rated:** save energy with our most efficient A rated appliances
- **Speed Perfect:** Cuts the cycle time by up to 65%* without compromising on results.
- **Super Quick 30:** Faster washing when you need it.
- **Iron Assist:** Reduces wrinkles and your ironing pile
- **Anti Stain:** reliably removes four of the most common stains.

Technical Data

Energy Efficiency Class ¹ : A
Weighted energy consumption in kWh per 100 washing cycles of eco 40-60 programme: 51 kWh/100 cycles
Rated capacity, in kg, for the eco programme at full load (EU 2017/1369): 10.0 kg
The water consumption of the eco programme in liters per cycle:	50 l
Duration of eco 40-60 programme in hours and mins at rated capacity: 3:50 h
Spin-drying efficiency class of eco 40-60 programme: B
Airborne acoustical noise emission class: B
Airborne acoustical noise emissions : 74 dB(A) re 1pW
Built-in / Free-standing: Freestanding
Dimensions of the product: 845x598x588 mm
Net weight: 75.9 kg
Connection rating: 2300 W
Fuse protection: 10 A
Voltage: 220-240 V
Frequency: 50-60 Hz
Length electrical supply cord: 210 cm
Door hinge: Left
Wheels: No
EAN code: 4242005413102
Installation typology: Free-standing

Optional accessories

- WMZ2200 Floor securing component
- WMZ2381 Extension for cold water inlet /Aquastop
- WMZMPF10 Microplastic Filter



¹ Scale of Energy Efficiency Classes from A to G

Series 6, Washing machine, front loader, 10 kg, max. 1400 rpm WGG254F0GB

Perfect results with minimum detergent and water consumption thanks to i-DOS automatic dosing and ActiveWater Plus.

Performance

- Energy Efficiency Class¹: A
- Energy² / Water³: 51 kWh / 50 litres
- Load capacity: 1 - 10 kg
- Programme duration⁴: 3:50 h:min
- Spin drying efficiency class: B
- Spin speed^{**}: 400 - 1400 rpm
- Noise level: 74 dB (A) re 1 pW
- Noise efficiency class: B

Programmes/functions

- Standard programmes: cottons, easy care, delicates, wool hand wash
- Series / project: W_F55-CA10-Ahi-i
- Iron Assist: Steam programme that reduces wrinkles on dry clothes
- Special programmes: Automatic Gentle, Automatic, Drum clean with reminder, Drain / Spin, Mixed Load, Single Rinse, Super Quick 15/30, Hygiene

Key features

- SpeedPerfect: perfectly clean in up to 65% less time. ***
- i-DOS: automatic dosing of liquid detergent and softener
- AntiStain - 4 stain removal options at the touch of a button
- Touch control buttons: Reduced Ironing option, Ready in, stain selection, i-DOS 2.0, start/pause with reload function, Temperature selection, SpeedPerfect, Prewash, Spin speed reduction/Rinse Hold

Additional features

- Reload function: Flexibility to add or remove laundry items of any size even after start of the wash cycle.
- Large LED-Display for programme status indication, max. spin speed, remaining time and 24 h end time delay and load recommendation
- Hygiene Plus: clean laundry and effective removal of germs
- Drum volume: 70 litres
- Usage meter: counts completed programmes
- no
- VarioDrum: gentle and efficient washing
- Drum clean with reminder function
- Large black-blackgrey door with 160° opening
- Reload function: Flexibility in adding laundry items into the drum, even after the wash cycle has started.
- EcoSilence drive with 10 year warranty
- EcoSilence drive with 10 year warranty
- ActiveWater Plus: for highly efficient use of water even with smaller loads thanks to automatic load detection.
- AntiStain
- AntiVibration Design - for more stability and quietness
- Turbidity sensor

- Aqua Protection
- soft dial
- Foam detection system
- Safeguard monitoring system adjusts load distribution and programme settings to protect clothes
- Child lock
- Acoustic signals: Buzzer
- Detergent dispensing: i-DOS 2.0

Technical Information

- Slide-under installation
- Dimensions (H x W): 84.5 cm x 59.8 cm
- Appliance depth: 58.8 cm
- Appliance depth incl. door: 63.2 cm
- Appliance depth with open door: 104.9 cm

¹ Scale of Energy Efficiency Classes from A to G

² Energy consumption in kWh per 100 cycles (in programme Eco 40-60)

³ Weighted water consumption in litres per cycle (in programme Eco 40-60)

⁴ Duration of Eco 40-60 programme

** The maximum spin speed is automatically reduced in the case of laundry imbalances.

*** Comparison between the program duration of Easy-care 40°C and the program duration of Easy-care 40°C + activated Speed option

**Series 6, Washing machine, front loader, 10 kg, max. 1400 rpm
WGG254F0GB**

Measurements in mm

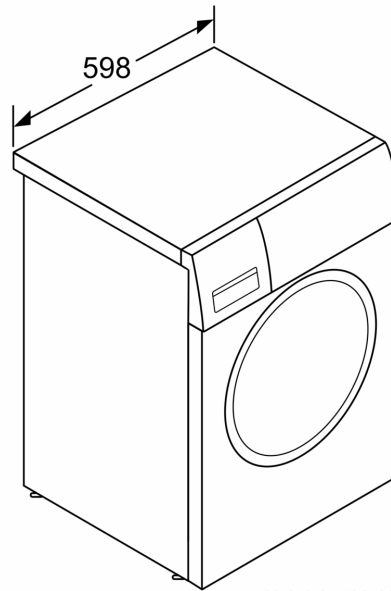
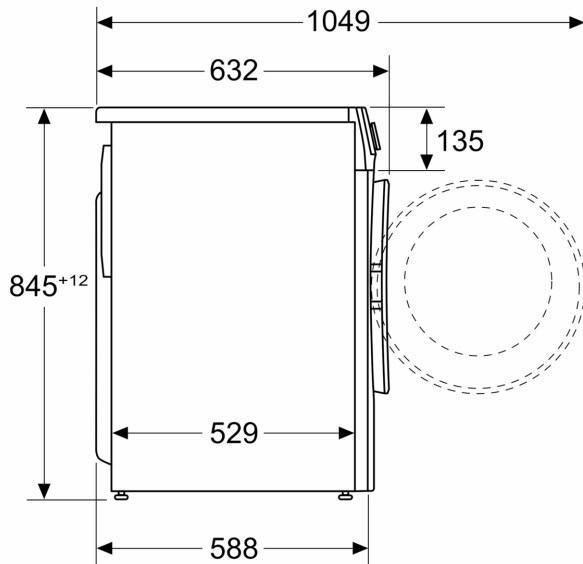

measurements in mm