

Series 4, Fully-integrated dishwasher, 60 cm, Variable hinge SMH4HTX02G



Optional accessories

SGZ0BI02	decorative strips stainless steel 81,5cm
SGZ0CL01	door lock mechanical, straight
SGZ1010	inlet and outlet hose extension
SGZ8BI00	Connection rail for divided furniture
SMZ5300	GlassSecure Tray

Vario Hinge connected dishwasher with noise reduction at any time via the Home Connect App perfect even for kitchens with low plinth heights and high built in situations.

- **Extra Dry:** extra drying option for difficult-to-dry loads.
- **Silence on demand:** up to 30 min noise reduction at any time via the Home Connect App.
- **Height Adjustable Top Basket:** offers extra space, especially for tall dishes.
- **Home Connect:** an easy solution to help you get the most out of your appliance, with flexible control and additional features.
- **EcoSilence Drive:** especially energy-saving and silent in operation with a particularly high life span.

Technical Data

Energy Efficiency Class ¹ :D
Energy Consumption for 100 cycles Eco Programme ² : 84 kWh/100 cycles
Maximum number of place settings: 13
The water consumption of the eco programme in liters per cycle:	9.0 l
Programme duration ³ : 4:30 h
Airborne acoustical noise emissions : 46 dB(A) re 1pW
Airborne acoustical noise emission class:C
Built-in / Free-standing: Built-in
Height of removable worktop: 0 mm
Required niche size for installation (HxWxD): 815-875 x 600 x 550 mm
Depth with open door 90 degree: 1150 mm
Adjustable feet: Yes - all from front
Maximum adjustability feet: 60 mm
Adjustable plinth: Both horizontal and vertical
Net weight: 33.1 kg
Gross weight: 34.9 kg
Connection rating: 2400 W
Fuse protection: 10 A
Voltage: 220-240 V
Frequency: 50; 60 Hz
Length electrical supply cord: 175 cm
Plug type: GB plug
Length inlet hose: 165 cm
Length outlet hose: 190 cm
EAN code: 4242005472437
Installation typology: Integrated



¹ Scale of Energy Efficiency Classes from A to G
² Energy consumption in kWh per 100 cycles (in programme Eco 50 °C)
³ Duration of programme Eco 50 °C

Series 4, Fully-integrated dishwasher, 60 cm, Variable hinge SMH4HTX02G

Vario Hinge connected dishwasher with noise reduction at any time via the Home Connect App perfect even for kitchens with low plinth heights and high built in situations.

- Self-cleaning filter system with 3 piece corrugated filter
- incl. Steam protection for worktop
- Stainless steel/Polinox interior
- Dimensions (HxWxD): 81.5 x 59.8 x 55cm

¹ Scale of Energy Efficiency Classes from A to G

² Energy consumption in kWh per 100 cycles (in programme Eco 50 °C)

³ Water consumption in litres per cycle (in programme Eco 50 °C)

⁴ Duration of programme Eco 50 °C

Performance

- Energy Efficiency Class¹: D
- Energy² / Water³: 84 kWh / 9 litres
- Capacity: 13 place settings
- Programme duration⁴: 4:30 (h:min)
- Noise level: 46 dB(A) re 1 pW
- Noise Efficiency Class: C

Programmes / functions

- 6 programmes: Eco 50 °C, Auto 45-65 °C, Intensive 70 °C, Express 65°, Glass 40 °C, Favourite
- Default favourite programme: Pre-Rinse
- 4 special options: Remote Start, Extra Dry, Half Load, SpeedPerfect+
- Add-On functions via Home Connect app: Hygiene+, Silence on Demand
- Machine Care

Flexible design elements

- Vario baskets
- Height adjustable top basket when empty
- Low friction wheels on bottom basket
- Rack Stopper to prevent derailing of bottom basket
- 2 foldable plate racks in bottom basket
- Knife rack in top basket
- Cutlery basket in lower rack
- Upper rack cup shelf

Innovations and technology

- Home Connect ready on WLAN
- Heat exchanger - Hygienic and efficient drying
- DosageAssist detergent dispenser
- EcoSilence BLDC drive
- Automatic detergent detection
- AquaSensor III
- AquaMix - Glass protection system

Design features

- VarioHinge 50mm
- Push button top edge controls
- InfoLight (Red) - Light projection on the floor
- Time delay (3, 6 or 24 hours)
- Acoustic end of cycle indicator
- AquaStop: Bosch's warranty in case of water damage - for the lifetime of the appliance. Please find warranty terms under <https://www.bosch-home.co.uk/customer-service/care-protection-and-parts/additional-warranties>

Series 4, Fully-integrated dishwasher, 60 cm, Variable hinge SMH4HTX02G

measurements in mm



⌘ socket
() values with extension kit

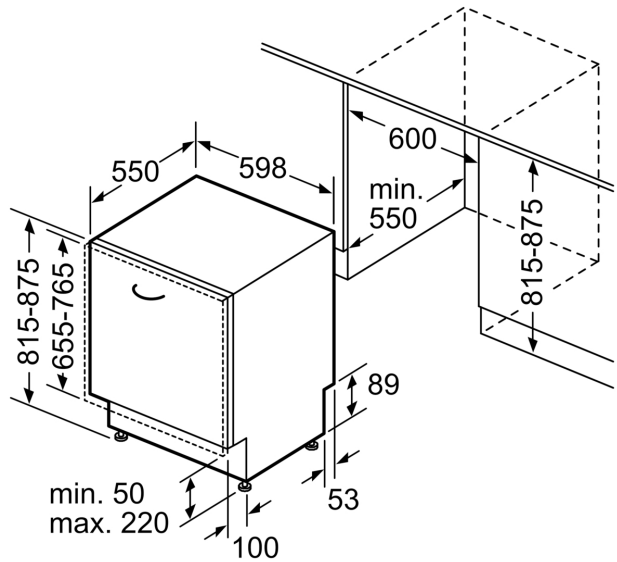

measurements in mm