

Montpellier

THE PERFECT BALANCE OF FUNCTION AND STYLE
LAUNDRY - DISHWASHING - COOKING - COOLING

Installation and Operating Instructions



Tall No Frost Larder Fridge

MTL362X - Inox

Please read these instructions carefully before attempting to install or use this appliance.
We recommend that you keep these instructions in a safe place for future reference.

Welcome

Thank you for choosing this Montpellier appliance.

Our appliances have been designed to provide you with the best combination of style, reliability and performance to give you years of trouble-free use.

You may be familiar with a similar product, but please take time to read these instructions carefully before installing or using your appliance to ensure you get the most from your purchase.



2
YEAR
GUARANTEE
— PARTS & LABOUR —
ACROSS ALL OUR MODELS
Montpellier
www.montpellier-appliances.com

We recommend that you keep this manual in a safe place for future reference.

Your appliance is covered by a comprehensive two year Parts & Labour Guarantee. In the unlikely event that you experience a problem with your appliance, you can rest assured that you are fully protected against the cost of repairs for the first 24 months. Please note that any claim must be accompanied by the model reference number, serial number and proof of purchase.

To activate your guarantee, you will need your product serial number. This can be found inside your appliance.

NB: Please make sure that you keep a copy of your original sales invoice as this will be needed if any service call is required.

There are three ways to register your Guarantee:

- **Online:** Visit the Support page on our website and complete the online Product Registration form. www.montpellier-appliances.com
- **By Post:** Simply detach and fill in the form provided, attach a stamp and send it in the post. Don't forget to include your e-mail address so that we can send confirmation through to you.
- **By Phone:** Contact our warranty registration department on **0808 1961388**

Thank you for choosing this product.

This User Manual contains important safety information and instructions on the operation and maintenance of your appliance.

Please take the time to read this User Manual before using your appliance and keep this book for future reference.

The design and specifications are subject to change without prior notice for product improvement.

CONTENTS

1 Safety warnings

1.1 Warning	1-2
1.2 Meanings of safety warning symbols	3
1.3 Electricity related warnings	3
1.4 Warnings for using	4
1.5 Warnings for placement	4-5
1.6 Warnings for energy	5
1.7 Warnings for disposal	5

2 Proper use of the refrigerator

2.1 Placement	6
2.2 Door handle installation	7
2.3 Levelling feet	8
2.4 Door Right-Left Change (optional)	9-10
2.5 Starting	11
2.6 Energy saving tips	11

3 Structure and functions

3.1 Key components	12
3.2 Functions	13-14
3.3 Water Dispenser	15-16

4 Maintenance and care of the refrigerator

4.1 Overall cleaning	17
4.2 Defrosting	17
4.3 Out of operation	17

5 Trouble shooting	18
--------------------	----

1 Safety warnings

1.1 Warning



This appliance is intended to be used in household and domestic applications only.

The appliance should be allowed to stand upright for a minimum of 4 hours before being turned on for the first time or after being moved to another position.

This appliance is not intended for use by persons (including children) with reduced physical, sensory or mental capabilities, or lack of experience and knowledge, unless they have been given supervision or instruction concerning use of the appliance by a person responsible for their safety.)

Children should be supervised to ensure that they do not play with the appliance.

If the supply cord is damaged, it must be replaced by the manufacturer, its service agent or similarly qualified persons in order to avoid a hazard.

Do not store explosive substances such as aerosol cans with a flammable propellant in this appliance.

The appliance has to be unplugged after use and before carrying out user maintenance on the appliance.

WARNING Keep ventilation openings in the appliance enclosure clear of obstruction.

WARNING Do not use mechanical devices or other means to accelerate the defrosting process, other than those recommended by the manufacturer.

WARNING Do not damage the refrigerant circuit.

WARNING Do not use electrical appliances inside the food storage compartments of the appliance, unless they are of the type recommended by the manufacturer.

WARNING Please abandon the refrigerator according to local regulators for it uses flammable blowing gas and refrigerant.

WARNING When positioning the appliance, ensure the supply cord is not trapped or damaged.

WARNING Do not locate multiple portable socket-outlets or portable power supplies at the rear of the appliance.

Do not use extension cords or ungrounded (two prong) adapters.

DANGER Risk of child entrapment. Before you throw away your old refrigerator or freezer:

- Take off the doors.
- Leave the shelves in place so that children may not easily climb inside.

The refrigerator must be disconnected from the source of electrical supply before attempting the installation of accessory.

For a freestanding appliance: This refrigerating appliance is not intended to be used as a built-in appliance.

Refrigerant and cyclopentane foaming material used for the appliance are flammable. Therefore, when the appliance is scrapped, it should be kept away from any fire source and be recovered by a specialised recovering company with corresponding qualifications, other than be disposed by combustion, so as to prevent damage to the environment or any other harm.

For EN standard: This appliance can be used by children aged from 8 years and above and persons with reduced physical sensory or mental capabilities or lack of experience and knowledge, if they have been given supervision or instruction concerning use of the appliance in a safe way and understand the hazards involved. Children shall not play with the appliance. Cleaning and user maintenance shall not be made by children without supervision. Children aged from 3 to 8 years are allowed to load and unload refrigerating appliances.

The necessity that, for doors or lids fitted with locks and keys, the keys be kept out of the reach of children and not in the vicinity of the refrigerating appliance, in order to prevent children from being locked inside.

To avoid contamination of food, please respect the following instructions:

- Opening the door for long periods can cause a significant increase of the temperature in the compartments of the appliance.
- Clean regularly surfaces that can come in contact with food and accessible drainage systems.
- Clean water tanks if they have not been used for 48h; flush the water system if water has not been drawn for 5 days.
- Store raw meat and fish in suitable containers in the refrigerator, so that it is not in contact with or drips onto other food.
- If the refrigerating appliance is left empty for long periods, switch off, defrost, clean, dry, and leave the door open to prevent mould developing within the appliance.

1.2 Meaning of safety warning symbols



Prohibition symbol

This is a prohibition symbol. Any incompletion with instructions marked with this symbol may result in damage to the product or endanger the personal safety of the user.



Warning symbol

This is a warning symbol. It is required to operate in strict observance of instructions marked with this symbol; or otherwise damage to the product or personal injury may be caused.



Note symbol

This is a cautioning symbol. Instructions marked with this symbol require special caution. Insufficient caution may result in slight or moderate injury, or damage to the product.

(This manual contains lots of important safety information which shall be observed by the users.)

1.3 Electricity related warnings

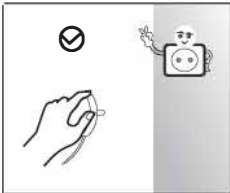

- Do not pull the power cord when pulling the power plug of the refrigerator. Please firmly grasp the plug and pull out it from the socket directly.
- To ensure safe use, do not damage the power cord or use the power cord when it is damaged or worn.

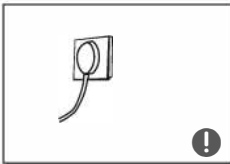

- Please use a dedicated power socket and the power socket shall not be shared with other electrical appliances.
- The power plug should be firmly contacted with the socket or else fires might be caused. Please ensure that the grounding electrode of the power socket is equipped with a reliable grounding line.

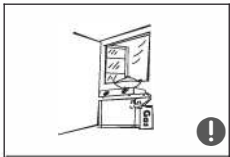

- Please turn off the valve of the leaking gas and then open the doors and windows in case of leakage of gas and other flammable gases.
- Do not unplug the refrigerator and other electrical appliances considering that spark may cause a fire.

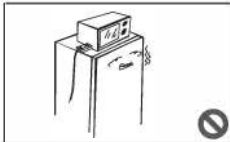

- It is recommended not to place electrical appliances such as power socket, voltage regulator, rice cooker, microwave oven etc. on the top of the refrigerator.

1.4 Warnings for using

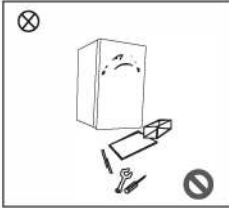

- Do not arbitrarily disassemble or reconstruct the refrigerator, nor damage the refrigerant circuit; maintenance of the appliance must be conducted by a specialist.
- Damaged power cord must be replaced by the manufacturer, its maintenance department or related professionals in order to avoid danger.

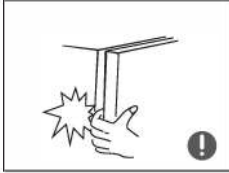

- The gaps between refrigerator doors and between doors and refrigerator body are small, be noted not to put your hand in these areas to prevent from squeezing the finger. Please be gentle when close or open the refrigerator door to avoid falling articles.



- Do not pick foods or containers with wet hands in the freezing chamber when the refrigerator is running, especially metal containers in order to avoid frostbite.

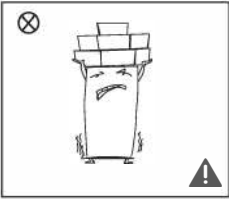

- Do not allow any child to get into or climb the refrigerator; otherwise suffocation or falling injury of the child may be caused.
- Do not place heavy objects on the top of the refrigerator considering that objects may fall when close or open the door, and accidental injuries might be caused.
- Please pull out the plug in case of power failure or cleaning. Do not connect the freezer to power supply within five minutes to prevent damages to the compressor due to successive starts.

1.5 Warnings for placement

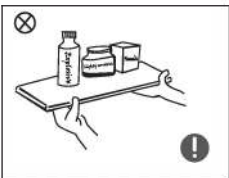

- Do not put flammable, explosive, volatile and highly corrosive items in the refrigerator to prevent damages to the product or fire accidents.
- Do not place flammable items near the refrigerator to avoid fires.

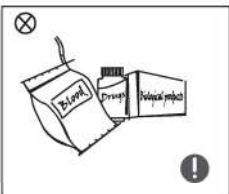

- The refrigerator is intended for household use, such as storage of foods; it shall not be used for other purposes, such as storage of blood, drugs or biological products, etc.



- Do not store beer, beverage or other fluid contained in bottles or enclosed containers in the freezing chamber of the refrigerator; or otherwise the bottles or enclosed containers may crack due to freezing to cause damages.

1.6 Warnings for energy

Warning for energy

1) Refrigerating appliances might not operate consistently (possibility of defrosting of contents or temperature becoming too warm in the frozen food compartment) when sited for an extended period of time below the cold end of the range of temperatures for which the refrigerating appliance is designed.

2) The fact that effervescent drinks should not be stored in food freezer compartments or cabinets or in low-temperature compartments or cabinets, and that some products such as water ices should not be consumed too cold;

3) The need to not exceed the storage time(s) recommended by the food manufacturers for any kind of food and particularly for commercially quick-frozen food in food-freezer and frozen-food storage compartments or cabinets;

4) The precautions necessary to prevent an undue rise in the temperature of the frozen food while defrosting the refrigerating appliance, such as wrapping the frozen food in several layers of newspaper.

5) The fact that a rise in temperature of the frozen food during manual defrosting, maintenance or cleaning could shorten the storage life.

1.7 Warnings for disposal



Refrigerant and cyclopentane foaming material used for the refrigerator are flammable. Therefore, when the refrigerator is scrapped, it shall be kept away from any fire source and be recovered by a special recovering company with corresponding qualification other than be disposed by combustion, so as to prevent damage to the environment or any other harm.



When the refrigerator is scrapped, disassemble the doors, and remove gasket of door and shelves; put the doors and shelves in a proper place, so as to prevent trapping of any child.



Correct Disposal of this product

This marking indicates that this product should not be disposed with other household wastes. To prevent possible harm to the environment or human health from uncontrolled waste disposal, recycle it responsibly to promote the sustainable reuse of material resources. To return your used device, please use the return and collection systems or contact the retailer where the product was purchased. They can take this product for environmental safe recycling.

2 Proper use of refrigerators

2.1 Placement

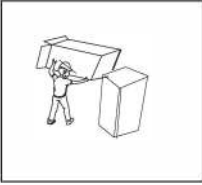

- Before use, remove all packing materials, including bottom cushions, foam pads and tapes inside of the refrigerator. Tear off the protective film on the doors and the refrigerator body.



- Keep away from heat and avoid direct sunlight. Do not place the refrigerator in moist or watery places to prevent rust or reduction of insulating effect.
- Do not spray or wash the refrigerator; do not put the refrigerator in moist places easy to be splashed with water so as not to affect the electrical insulation properties of the refrigerator.

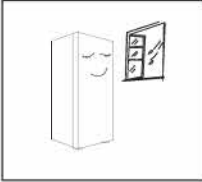

- The refrigerator is placed in a well-ventilated indoor place; the ground shall be flat, and sturdy (rotate left or right to adjust the feet for levelling if unstable).

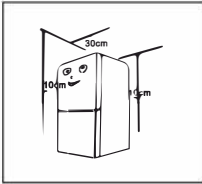

- The top space of the refrigerator shall be greater than 30cm, and the refrigerator should be placed against a wall with a free distance more than 10cm to facilitate heat dissipation.

! Precautions before installation:

Before installation or adjusting of accessories, it shall be ensured that the refrigerator is disconnected from power.

Precautions shall be taken to prevent fall of the handle from causing any personal injury.

2.2 Door handle installation

Precautions shall be taken to prevent fall of the handle from causing any personal injury.

Tools required by the user - Cross Head Screwdriver

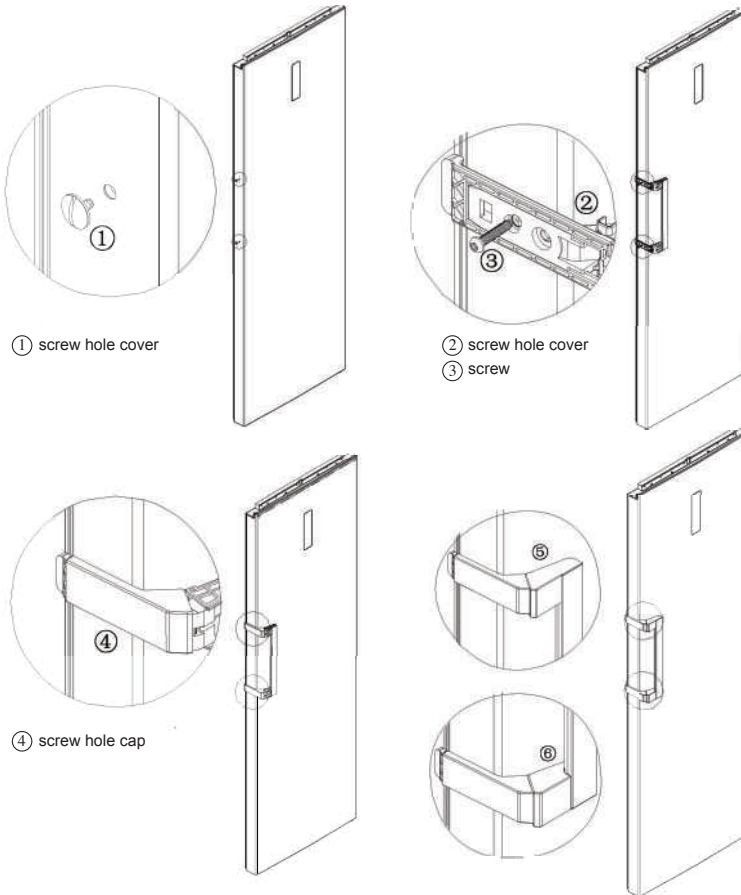

(The picture above is only for reference. The actual configuration will depend on the physical product or statement by the distributor)

Assembly steps

- Remove the screw hole caps (1) from the door, and use cross screwdriver to fix screws (3) into the screw hole (2) tightly.
- Assemble the screw hole cap (4) on the screw hole of handle.
- Once caps are fitted the door handle should slide over the top of the caps (5-6)
- The reverse operation is for disassembly.

2.3 Levelling feet

Schematic diagram of the levelling feet

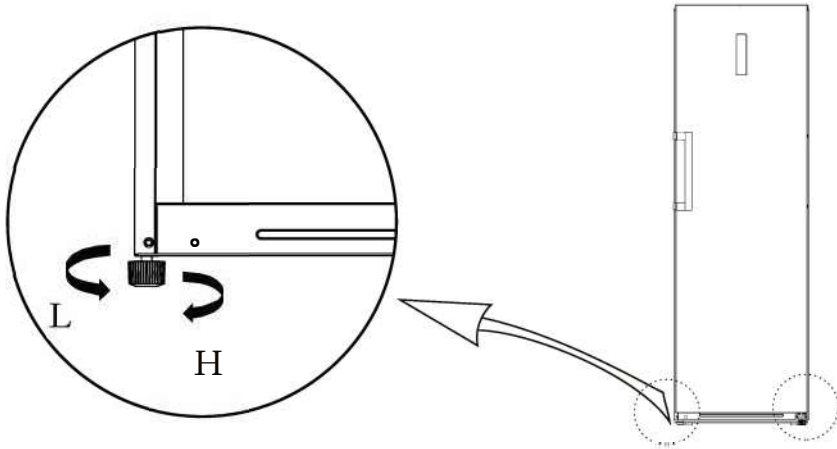





(The picture above is only for reference. The actual configuration will depend on the physical product or statement by the distributor)

Adjusting procedures:

- a. Turn the feet clockwise to raise the refrigerator;
- b. Turn the feet counterclockwise to lower the refrigerator;
- c. Adjust the right and left feet based on the procedures above to a horizontal level.

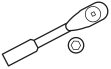
2.4 Door Right-Left Change (Optional)

List of tools to be provided by the user			
	Cross screwdriver		Putty knife thin-blade screwdriver
	5/16" socket and ratchet		Masking tape

- 1) Power off the refrigerator, remove all objects from the door trays.
- 2) Remove the screw hole caps, screws and handle and remove the plastic screw hole caps from the other side. Refer to chapter 2.2
- 3) Remove the upper hole cover, upper hinge cover (3), screws and upper hinge. Unplug the wiring connector on the right side of the refrigerator top (1-2).

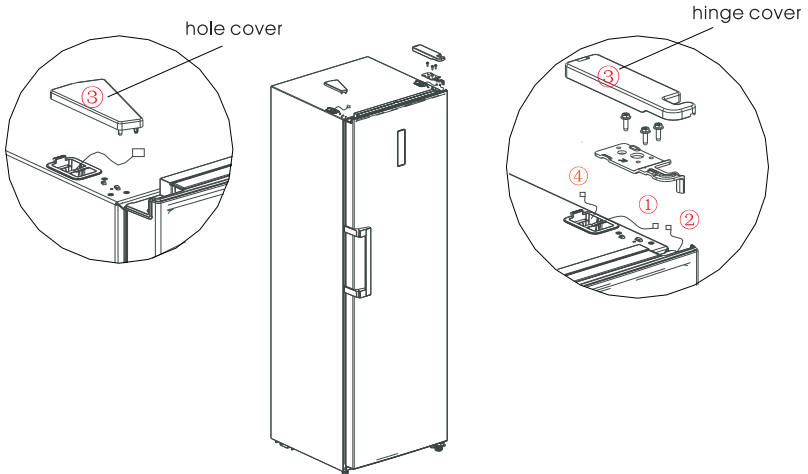

- 4) Remove the door and place safely on one side until ready to re-fit. Remove the lower hinge shaft, bracket and adjustable foot. Assemble the shaft and adjustable foot on the other side of the hinge bracket and then re-fit the whole assembly on the other side of the refrigerator.

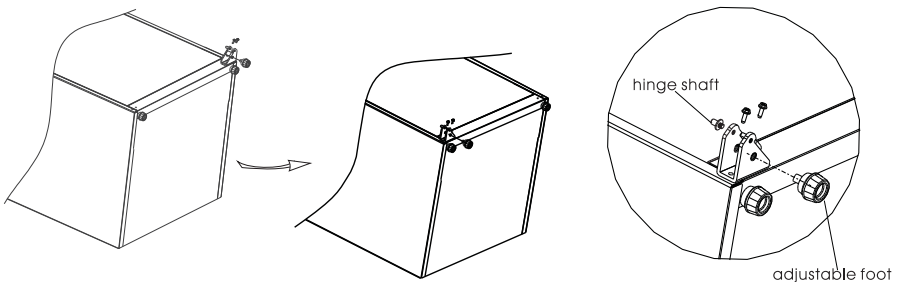

5) Remove the door end cover, install the upper hinge sleeve and door signal line to the other side and install the door end cover.
 Dismantle the door stopper sleeve pipe from the right bottom of door, insert the sleeve pipe into hinge hole of left bottom of door, assemble door stopper on left bottom of door.

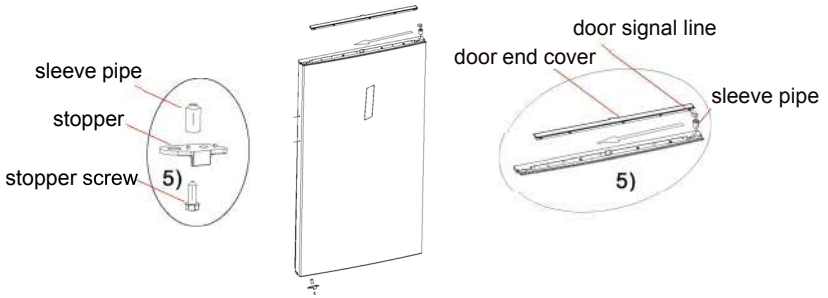

6) Take out the left top hinge, left top hinge cover from accessories package, place the door on the bottom hinge, and mount the left top hinge. Connect signal line terminal (2) with signal line terminal (3), connect signal line terminal (1) with signal line terminal (4), mount top hinge cover and hole cover.

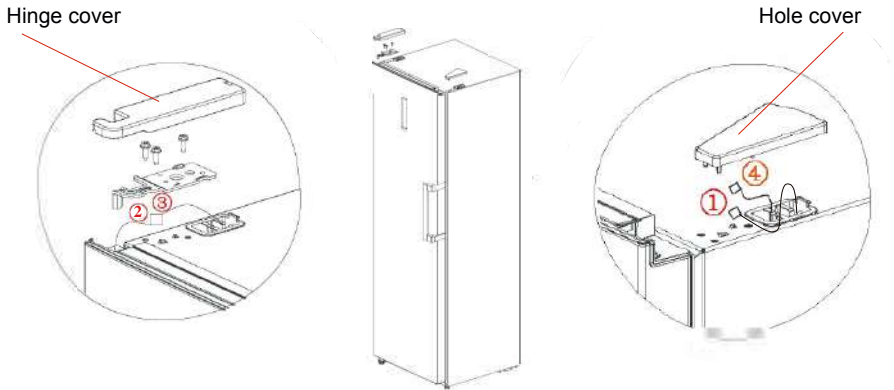

7) For the assembly of handle, please refer to chapter 2.2.



2.5 Starting

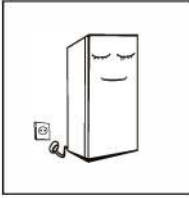

- Before initial start, keep the refrigerator still for two hours before connecting it to power supply.
- Before putting any fresh or frozen foods, the refrigerator shall have run for 2-3 hours, or for above 4 hours in summer when the ambient temperature is high.

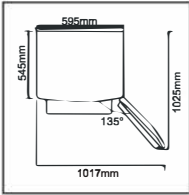

- Spare enough space for convenient opening of the doors and drawers or it is subject to distributor statement.

2.6 Energy saving tips

- The appliance should be located in the coolest area of the room, away from heat producing appliances or heating ducts, and out of the direct sunlight.
- Let hot foods cool to room temperature before placing in the appliance. Overloading the appliance forces the compressor to run longer. Foods that freeze too slowly may lose quality, or spoil.
- Be sure to wrap foods properly, and wipe containers dry before placing them in the appliance. This cuts down on frost build-up inside the appliance.
- Appliance storage bin should not be lined with aluminum foil, wax paper, or paper toweling. Liners interfere with cold air circulation, making the appliance less efficient.
- Organize and label food to reduce door openings and extended searches. Remove as many items as needed at one time, and close the door as soon as possible.

3 Structure and functions

3.1 Key components

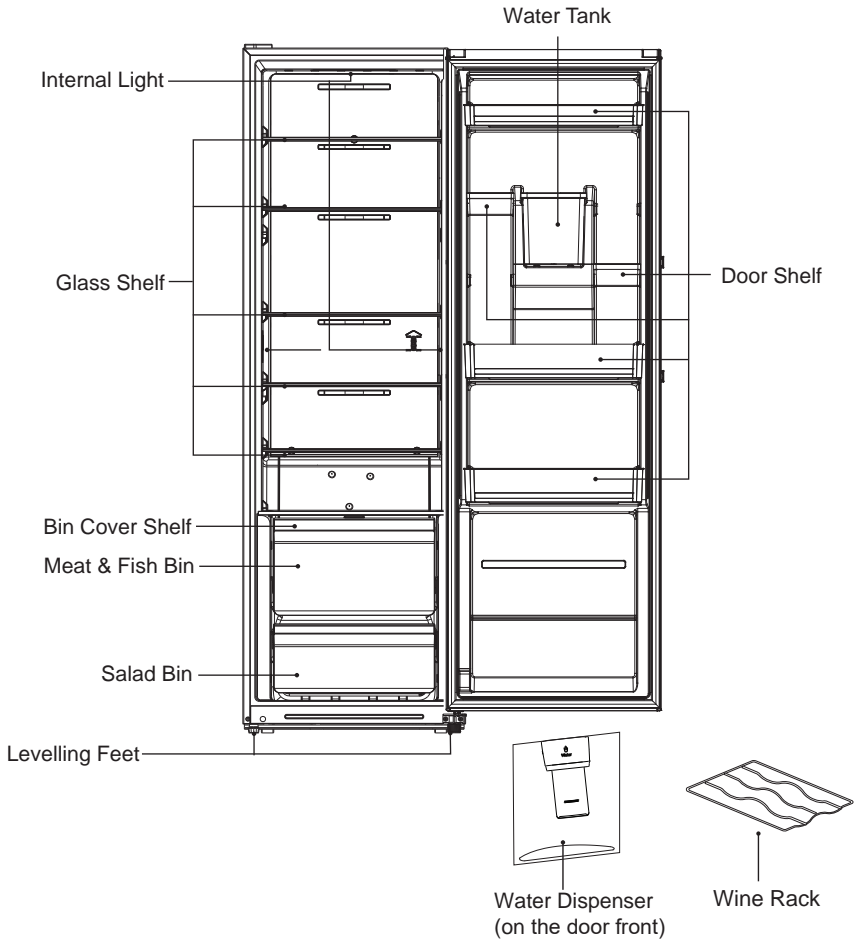

Refrigerating chamber

- The Refrigerating Chamber is suitable for storage of a variety of fruits, vegetables, beverages and other food consumed in the short term, suggested storage time 3 days to 5 days. Cooked foods shall not be put in the refrigerating chamber until cooled to room temperature.
- Foods are recommended to be sealed up before putting into the refrigerator.
- The glass shelves can be adjusted up or down for a reasonable amount of storage space and easy use.

3.2 Functions

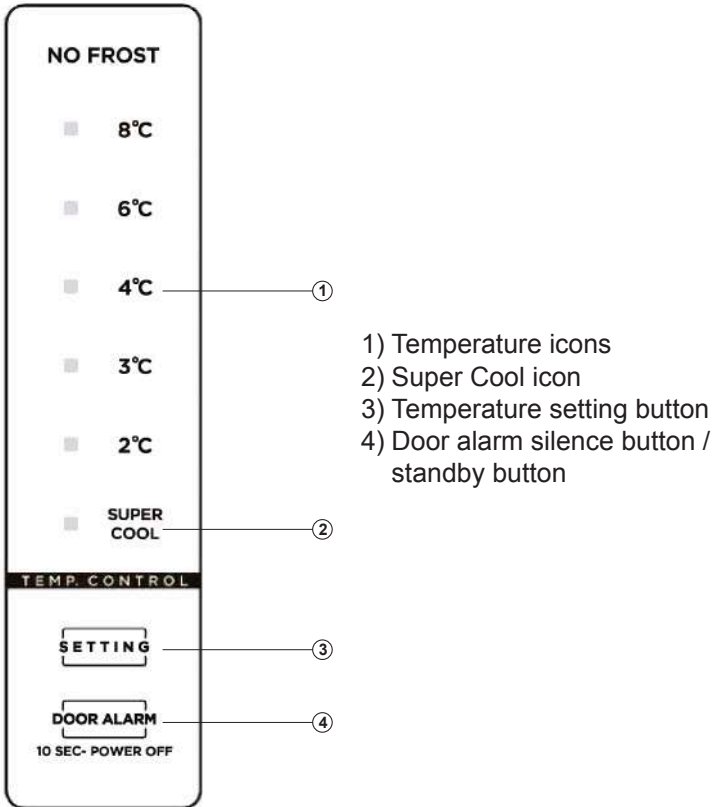

When the fridge power is on:

All temperature icons shine within 3s after power on, for power on at the first time, the default set temperature is 4C.

After that, every time you start the fridge, it will run in accordance with the set temperature before last power off.

Temperature Setting

To change the temperature simply press the **"SETTING"** button repeatedly until you reach the required temperature. If you pass your required setting just continue to press the button as it will carry on going through the temperatures until you get to your required temperature. The refrigerator will run to the required setting 15s after the final press of the button.

Super cool mode.

To place the fridge in Super Cool mode press the **"SETTING"** button repeatedly until you reach the **"SUPER COOL"** icon. If you pass your required setting just continue to press the button as it will carry on going through the temperatures until you get to the Super Cool icon again. The refrigerator will run to the set temperature of 2°C before automatically turning itself off after 360 minutes then returning to the previous set temperature.

If you need to cancel the Super Cool mode at any time simply press the SETTING button to revert to your required temperature.

Door Alarm.

If the door is left open for a prolonged period of time an alarm will sound to warn you the door needs closing.

If you have the door open and wish to cancel the alarm simply press the **"DOOR ALARM"** button on the display panel and this will cancel the alarm. Once the door is closed this will reset the alarm incase the door is left open again.

Standby Function

Press the **"DOOR ALARM"** button on the display panel for approx 10seconds to put the fridge in **"Standby Mode"**. Standby Mode will turn off the appliance so make sure that the fridge is empty. To get the fridge out of "Standby Mode" simply press the "Setting button" to the required temperature.

It is not advisable to use this mode for a prolonged shut down, if that is the case then the fridge should be unplugged.

Display of Error Codes.

On the occurrence of a failure, the temperature icons will give a combined blink to correspond with the below error codes.
If No failure then the display will display the set temperature.

Error Code	Error Description	Display
E1	Fridge temperature sensor failure	SUPER COOL Icon and 2°C Icon will shine at the same time
E5	Fridge defrost sensor failure	SUPER COOL Icon and 3°C Icon will shine at the same time
E6	Communication Error	2°C and the 4°C Icon will shine at the same time
E7	Ambient temperature sensor failure	SUPER COOL Icon and 4°C Icon will shine at the same time

3.3 Water Dispenser

Water dispenser installation

Before using the water dispenser, clean the water tank first.

1. Take out the water tank by gripping it tightly on both sides, then slide the water tank out from the door.

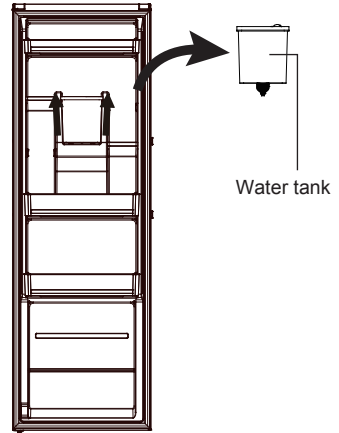

2. Take off the valve, and then the water tank cover. Wash the water tank, valve, lid and cover.

3. After washing, drain the water from inside the tank and replace the lid and cover.

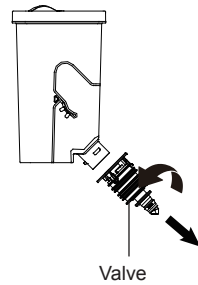

4. Insert the water tank valve into the water dispenser hole first.

5. Fit the water tank along the guides on the door. Press down on both sides of the water tank.

6. When a click is heard, that means the installation is completed.

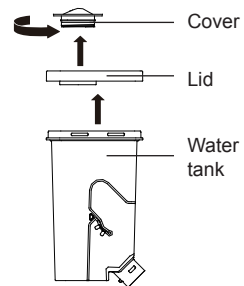

Be careful not to press on the tank valve

Filling the water tank

Open the cover of the water tank. Fill drinking water into the water tank through the hole. Close the cover after filling.

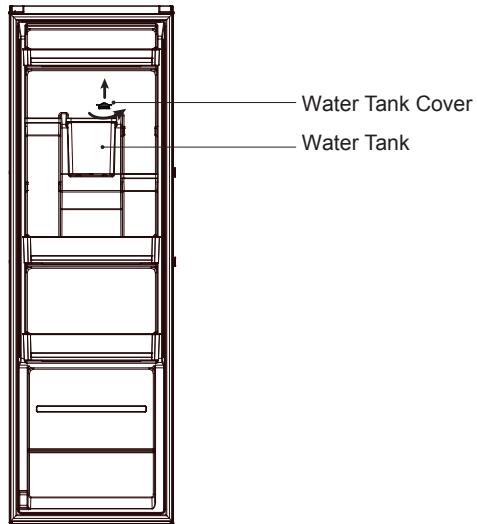

- Do not fill above the level, otherwise, it may overflow.
- Before filling with water, ensure that the water tank is steady and in a correct position.
- Apart from drinking water, other beverages (such as milk, juice, carbonated beverage, etc) are not suggested to be used, especially beverages that include grain must not be used (may result in blockage and damage).
- Hot water must not be filled into the water tank directly.
- Do not touch other parts of the unit when filling water, it may lead to leakage.

Receiving water from the water dispenser

- You should use the type of container that can fit under the water dispenser. Place the container properly underneath and push on the lever for water to flow.

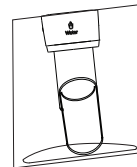

Cleaning the water tank and water dispenser

- Remove the water tank. Wash the tank, tank cover, small cap and valve lightly under water.
- After cleaning, dry them thoroughly before installing back in the fridge.
- Wipe the receiving base of the water dispenser with dry towel regularly to avoid overflowing.

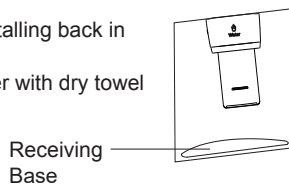

4. Maintenance and care of the appliance

4.1 Overall cleaning

- Dusts behind the refrigerator and on the ground shall be timely cleaned to improve the cooling effect and energy saving.
- Check the door gasket regularly to make sure there are no debris. Clean the door gasket with a soft cloth dampened with soapy water or diluted detergent.
- The interior of the refrigerator should be cleaned regularly to avoid odor.
- Please turn off the power before cleaning interior, remove all foods, drinks ,shelves, drawers, etc.
- Use a soft cloth or sponge to clean the inside of the refrigerator, with two tablespoons of baking soda and a quart of warm water. Then rinse with water and wipe clean. After cleaning, open the door and let it dry naturally before turning on the power.
- For areas that are difficult to clean in the refrigerator (such as narrow sandwiches, gaps or corners), it is recommended to wipe them regularly with a soft rag, soft brush, etc. and when necessary, combined with some auxiliary tools (such as thin sticks) to ensure no contaminants or bacterials accumulation in these areas.
- Do not use soap, detergent, scrub powder, spray cleaner, etc., as these may cause odors in the interior of the refrigerator or contaminated food.
- Clean the bottle frame, shelves and drawers with a soft cloth dampened with soapy water or diluted detergent. Dry with a soft cloth or dry naturally.
- Wipe the outer surface of the refrigerator with a soft cloth dampened with soapy water, detergent, etc., and then wipe dry.
- Do not use hard brushes, clean steel balls, wire brushes, abrasives (such as toothpastes), organic solvents (such as alcohol, acetone, banana oil, etc.), boiling water, acid or alkaline items, which may damage the fridge surface and interior. Boiling water and organic solvents such as benzene may deform or damage plastic parts.
- Do not rinse directly with water or other liquids during cleaning to avoid short circuits or affect electrical insulation after immersion.

Please unplug the refrigerator for defrost and cleaning.



4. 2 Defrosting

- The refrigerator is made based on the air-cooling principle and thus has automatic defrosting function. Frost formed due to change of season or temperature may also be manually removed by disconnection of the appliance from power supply or by wiping with a dry towel.

4.3 Out of operation

- Power failure: In case of power failure, even if it is in summer, foods inside the appliance can be kept for several hours; during the power failure, the times of door opening shall be reduced, and no more fresh food shall be put into the appliance.
- Long-lime nonuse: The appliance shall be unplugged and then cleaned; then the doors are left open to prevent odor.
- Moving: Before the refrigerator is moved, take all objects inside out, fix the glass partitions, vegetable holder, freezing chamber drawers and etc. with tape, and tighten the levelling feet; close the doors and fix them with tape. During moving, the appliance shall not be laid upside down or horizontally, or be vibrated; the inclination during movement shall be no more than 45°.

! The appliance shall run continuously once it is started. Generally, the operation of the appliance shall not be interrupted; otherwise the service life may be impaired

5 Trouble shooting

You may try to solve the following simple problems by yourself. If they cannot be solved, please contact the after-sales department.

Failed operation	<p>Check whether the appliance is connected to power or whether the plug is fully connected.</p> <p>Check whether the voltage is too low</p> <p>Check whether there is a power failure or partial circuits have tripped</p>
Odor	<p>Odorous foods shall be tightly wrapped.</p> <p>Check whether there is any rotten food.</p> <p>Clean the inside of the refrigerator</p>
Long-time operation of the compressor	<p>Long operation of the refrigerator is normal in summer when the ambient temperature is high</p> <p>It is not suggestible having too much food in the appliance at the same time Food should be cooled before being put into the appliance</p> <p>The doors are opened too frequently</p>
Light fails to get lit	<p>Check whether the refrigerator is connected to power supply and whether the illuminating light is damaged.</p> <p>Have the light replaced by a specialist</p>
Doors cannot be properly closed	<p>The door is stuck by food packages</p> <p>Too much food is placed inside the refrigerator</p> <p>The refrigerator is tilted</p>
Loud noise	<p>Check whether the floor is level and whether the refrigerator is placed stable.</p> <p>Check whether accessories are placed at proper locations</p>
Door seal fails to be tight	<p>Remove foreign matters on the door seal</p> <p>Heat the door seal and then cool it for restoration (or blow it with an electrical drier or use a hot towel for heating)</p>
Water pan overflows	<p>There is too much food in the chamber or food stored contains too much water, resulting in heavy defrosting</p> <p>The doors are not closed properly, resulting in frosting due to entry of air and increased water due to defrosting</p>
Hot housing	<p>Heat dissipation of the built-in condenser via the housing, which is normal, when housing becomes hot due to high ambient temperature, storage of too much food or shutdown of the compressor is shut down provide sound ventilation to facilitate heat dissipation</p>
Surface condensation	<p>Condensation on the exterior surface and door seals of the refrigerator is normal when the ambient humidity is too high. Just wipe the condensate with a clean towel.</p>
Abnormal noise	<p>Buzz: The compressor may produce buzzes during operation, and the buzzes are loud particularly upon start or stop. This is normal.</p> <p>Creak: Refrigerant flowing inside of the appliance may produce creak, which is normal.</p>

Table 1 Climate classes

Class	Symbol	Ambient temperature range °C
Extended Temperature	SN	+10 TO +32
Temperate	N	+16 TO +32
Subtropical	ST	+16 TO +38
Tropical	T	+16 TO +43

Climate class and meaning:

SN (extended temperate): This refrigerating appliance is intended to be used at ambient temperatures ranging from 10 °C to 32 °C.

N (temperate): This refrigerating appliance is intended to be used at ambient temperatures ranging from 16 °C to 32 °C.

ST (subtropical): This refrigerating appliance is intended to be used at ambient temperatures ranging from 16 °C to 38 °C.

T (tropical): This refrigerating appliance is intended to be used at ambient temperatures ranging from 16 °C to 43 °C.

YOU WILL FIND THE CLIMATE CLASS FOR YOUR APPLIANCE ON THE RATING PLATE

Ujcb`Zf`bYk`9i fcdYub`GHUfX

V@Á] a^Á acoÁ Á@Á ||| , ā * Áaa|Áaa Á^Á&~ ā^áÁ[{ Á&•q { ^!Á^!c&•È

Ordered Parted	Provided By	Minimum Time Required For provision.
Thermostats	Professional maintenance personnel	At least 7 years after the last model is launched on the market
Temperature Sensor	Professional maintenance personnel	At least 7 years after the last model is launched on the market
Printed Circuit board	Professional maintenance personnel	At least 7 years after the last model is launched on the market
Light Source	Professional repairers and final users	At least 7 years after the last model is launched on the market
Door Handles	Professional repairers and final users	At least 7 years after the last model is launched on the market
Door Hinges	Professional repairers and final users	At least 7 years after the last model is launched on the market
Trays	Professional repairers and final users	At least 7 years after the last model is launched on the market
Baskets	Professional repairers and final users	At least 7 years after the last model is launched on the market
Door gaskets	Professional repairers and final users	At least 10 years after the last model is launched on the market

Here For You

After-sales assistance

If you continue to experience problems with your appliance, please call the Montpellier customer service helpline on: **03333 234 473**

D'YUgY \ Uj Y' U'' nci f' dfcXi Wñ XYHJ]g' Uj U]UV`Yž]bWñ X]b[` h Y' a cXY' bi a Vyfž gYf]U' bi a Vyfž cf][]bU' gU'Yg']bj c]W' fWYUf' m' gl' ck]b[` a cXY' bi a VyfžXUH' cZ di fW Ugy' UbX' nci f' fYHJ]Yfjg' XYHJ]g' VYZ:fYfY[]ghYf]b[` UZU' `H'

The service call cannot progress without this information.

Your 2 year Manufacturer's guarantee

THIS DOES NOT AFFECT YOUR STATUTORY RIGHTS.

Your new Montpellier appliance carries a free guarantee which protects you against the cost of repairs during the first 24 months from date of purchase provided that:

Any claim is accompanied by evidence of the model reference, model serial number and proof of purchase, such as a Sales Receipt, showing that the appliance was purchased within the 24 months prior to the date of claim.

What is not covered under the Guarantee

- Any appliance not correctly installed and operated in accordance with the manufacturer's instructions
- Any appliance that is used for anything other than domestic purposes.
Any defect caused by accident, misuse, unauthorised modification or inexperienced repair.
- Cost of Call-out where a fault cannot be found with the appliance.
Cost of Call-out for work covering routine maintenance, such as, but not exclusively, cleaning of filters or defrosting.
- Cost of Call-out for work required to correct the alignment of doors following door reversal procedures carried out by you.
Use of the appliance by anyone other than the Householder.
Use in any commercial environment.
- Consumable items, such as, but not exclusively, fuses in plugs, bulbs and breakable items which require routine replacement.
Repair costs incurred that have not been authorised by Montpellier service and/or carried out by a non-approved Montpellier engineer.
- Montpellier Appliances do not accept claims for consequential loss, rusting, corroding, delivery damage or scratches.

YOUR GUARANTEE IS VALID ONLY IN THE UK & REPUBLIC OF IRELAND

To register your appliance simply complete the card in your appliance pack and return it with a stamp affixed. Alternatively you can register online at www.montpellier-appliances.com/support

SERVICE HELP-LINE

Should your appliance develop a fault, please call the Montpellier customer service helpline on:

03333 234 473

D'YUgYfYa Ya Vyf]c \ Uj Y'U' nci f' dfcXi WñXYHJ]g' Uj U]UV`Yž]bWñ X]b[` h Y'a cXY' bi a Vyfž gYf]U' bi a VyfžXUH' cZ di fW Ugy' UbX' nci f' fYHJ]Yfjg' XYHJ]g' VYZ:fYfY[]ghYf]b[` UZU' `H'

Montpellier Domestic Appliances Ltd.
Unit 1, Tewkesbury Retail Park, Northway Lane,
Tewkesbury, Gloucestershire GL20 8JU

www.montpellier-appliances.com



The symbol on the product or on its packaging indicates that this product may not be treated as household waste. Instead it shall be handed over to the applicable collection point for the recycling of electrical and electronic equipment. By ensuring this product is disposed of correctly, you will help prevent potential negative consequences for the environment and human health, which could otherwise be caused by inappropriate waste handling of this product. For more detailed information about recycling of this product, please contact your local city office, your household waste disposal service or the shop where you purchased the product.