

Montpellier

DOMESTIC APPLIANCES LTD

Installation & Operating Instructions



Undercounter Freezer *MDAUCFZ54W White*

Please read these instructions carefully before attempting to install or use this appliance.
We recommend that you keep these instructions in a safe place for future reference.

Thank you for choosing this Montpellier appliance.

Your appliance has been designed to provide you with the best combination of style, reliability and performance, to give you years of trouble-free use.

You may be familiar with a similar product, but please take the time to read these instructions carefully before installing or using your appliance to ensure that you get the most from your purchase and keep the manual for future reference.

The design and specifications are subject to change without prior notice for product development.

Your appliance is covered by a comprehensive two year Parts & Labour Guarantee. In the unlikely event that you experience a problem with your appliance, you can rest assured that you are fully protected against the cost of repairs for the first 24 months. Please note that any claim must be accompanied by the model reference number, serial number and proof of purchase.

To activate your guarantee, you will need your product serial number. This can be found inside your appliance.

NB: Please make sure that you keep a copy of your original sales invoice as this will be needed if any service call is required.

There are three ways to register your Guarantee:

Online: Visit the Support page on our website and complete the online Product Registration form.

www.montpellier-appliances.com

By Post: Simply detach and fill in the form provided, attach a stamp and send it in the post. Don't forget to include your e-mail address so that we can send confirmation through to you.

By Phone: Contact our warranty registration department on **08081 961 388**

Montpellier





montpellier-appliances.com

2

YEAR GUARANTEE

PARTS & LABOUR

ACROSS ALL OUR MODELS

Icon	Type	Meaning
	Warning	Serious injury or death risk
	Risk of electric shock	Dangerous voltage risk
	Fire	Warning, risk of fire / flammable materials
	Caution	Injury or property damage risk
	Important	Operating the system correctly

Warnings	4
Important Safety Instructions	5
Structure Illustration	10
Transportation	11
Installation	11
First Use	12
Test	13
Temperature Control	13
Storage of Food	14
Helpful Hints & Tips	17
Cleaning & Care	19
Door Reversal	20
Troubleshooting	24
Here For You	26

WARNING

Thank you for purchasing this high-quality product. We pay particular attention to the design, ergonomics and ease of use of our products. We hope that this device will give you complete satisfaction.

In the concern of a constant improvement of our products, we reserve the right to bring to their technical, functional or aesthetic characteristics any modifications related to their evolution.

Remark :

Because we are continuously improving our products, features and instructions for use can be modified without prior notice.

For more detailed information about the product, please flash the QR code on the energy label.



This product is for household use only!

Please read these instructions carefully before the first use of this product and save this manual for your future reference.

IMPORTANT SAFETY INSTRUCTIONS

This warning is only for EUROPEAN market only!

When using an electrical appliance, basic precautions should always be followed, including the following:

1. This appliance can be used by children aged from 8 years and above and persons with reduced physical, sensory or mental capabilities or lack of experience and knowledge if they have been given supervision or instruction concerning use of the appliance in a safe way and understand the hazards involved. Children shall not play with the appliance. Cleaning and user maintenance shall not be made by children without supervision.

2. Children aged from 3 to 8 years are allowed to load and unload refrigerating appliances.

3. If the supply cord is damaged, it must be replaced by the manufacturer, its service agent or similarly qualified persons in order to avoid a hazard.

4. **WARNING:** Keep ventilation openings, in the appliance enclosure or in the built-in structure, clear of obstruction.

5. **WARNING:** Do not use mechanical devices or other means to accelerate the defrosting process, other than those recommended by the manufacturer.

6. **WARNING:** Do not damage the refrigerant circuit.

7. **WARNING:** Do not use electrical appliances inside the

food storage compartments of the appliance, unless they are of the type recommended by the manufacturer.

8. Do not store explosive substances such as aerosol cans with a flammable propellant in this appliance.

9. This appliance is intended to be used in household and similar applications such as

- staff kitchen areas in shops, offices and other working environments;

- farm houses and by clients in hotels, motels and other residential type environments;

- bed and breakfast type environments;

- catering and similar non-retail applications.

10. Placed the appliance against a wall with a free distance not exceeding 75 mm and more than 50mm

11. **WARNING:** When positioning the appliance, ensure the supply cord is not trapped or damaged.

12. **WARNING:** Do not locate multiple portable socket-outlets or portable power supplies at the rear of the appliance.

13. To avoid contamination of food, please respect the following instructions:

- Opening the door for long periods can cause a significant increase of the temperature in the compartments of the appliance.

- Clean regularly surfaces that can come in contact with food and accessible drainage systems.

- Store raw meat and fish in suitable containers in the refrigerator, so that it is not in contact with or drip onto other food.

- Two-star frozen-food compartments are suitable for storing pre-frozen food, storing or making ice cream and making ice cubes.

- One-, two- and three-star compartments are not suitable for the freezing of fresh food.

– If the refrigerating appliance is left empty for long periods, switch off, defrost, clean, dry, and leave the door open to prevent mould developing within the appliance.

14. Unplug the appliance from outlet when not in use, before putting on or taking off parts, before cleaning.

15. Make sure to place the plug all the way into socket when connecting your appliance.

16. Insert the plug into a single grounded socket.

17. Never use the appliance in place where combustible and flammable materials are kept.

18. For safety reason, be sure to repair or replace parts at an authorized service dealers.

19. The motor is permanently lubricated and will require no oil.

20. The appliance must be positioned so that the plug is accessible.

21. Please adhere to local regulations regarding disposal of the appliance for its flammable blowing gas. Before you scrap the appliance, please take off the doors to prevent children trapped.

22. Ensure the refrigerator is unplugged before cleaning or if the product is not in use.

23. To clean the appliance use only mild detergents or glass cleaning products. Never use harsh detergents or solvents.

24. It is not recommended to use this refrigerator with an extension cord or power board. Please ensure that the appliance is plugged directly into the electrical outlet.

25. Do not place hot food or drink into the refrigerator before it cools down to room temperature.

26. Close the door immediately after putting in any items so the inside temperature will not rise dramatically.

27. Keep appliance away from any heat source or direct sunlight.

28. To fix stably, the appliance must be placed on a flat and solid surface. It should not be laid on any soft material.

29. Do not place any other appliance on top of the refrigerator, and do not get it wet.

30. To avoid injury or death from electrical shock do not operate the appliance with wet hands, while standing on a wet surface or while standing in water.

31. Do not use outdoors or in wet conditions.

32. Never pull the cord to disconnect it from the outlet. Grasp the plug and pull it from the outlet.

33. Keep the cord away from heated surfaces.

34. Check that the voltage of the power supply in your home is the same as the voltage shown on the rating label of this product.

35. Connect your refrigerator to an independent electrical socket and use a safe ground wire.

36. When the frost in freezer is removed, or when there is no electricity or when refrigerator ceases to be used, it should be cleaned in order to prevent it from smelling.

37. In the event of a power cut, turn off the electricity for a minimum of 5 minutes, otherwise the compressor may be damaged.

38. Children should be supervised to ensure that they do not play with the appliance.

39. The appliance is not intended to be operated by means of an external timer or a separate remote-control system.

40. This appliance has been incorporated with a grounded plug. Please ensure the wall outlet in your house is well earthed.

41. It is recommended to check regularly the supply cord for any sign of possible deterioration, and the appliance should not be used if the cable is damaged.

42. Replacing the LED light Please contact after service and do not replace it by user.

43. Regarding the information pertaining to the installation, handing, maintenance, servicing and disposal of the appliance, refer to the paragraphs “TRANSPORT AND HANDING” “INSTALLATION” “CLEANING AND CARE” “TROUBLESHOOTING” of the manual.

44. Disposal of the appliance: To prevent possible harm to the environment or human health from uncontrolled waste disposal, recycle it responsibly to promote the sustainable reuse of material resources. And the disposal should only be done through public collection points. Old refrigerators can contain CFC that destroy the ozone; contact the waste treatment center nearest your home for more details on the correct procedures for disposal.



45. **WARNING!** Risk of fire – flammable material. Please keep the product far away fire source during using, service and disposal. There are flammable materials at the back of the appliance.

STRUCTURE ILLUSTRATION

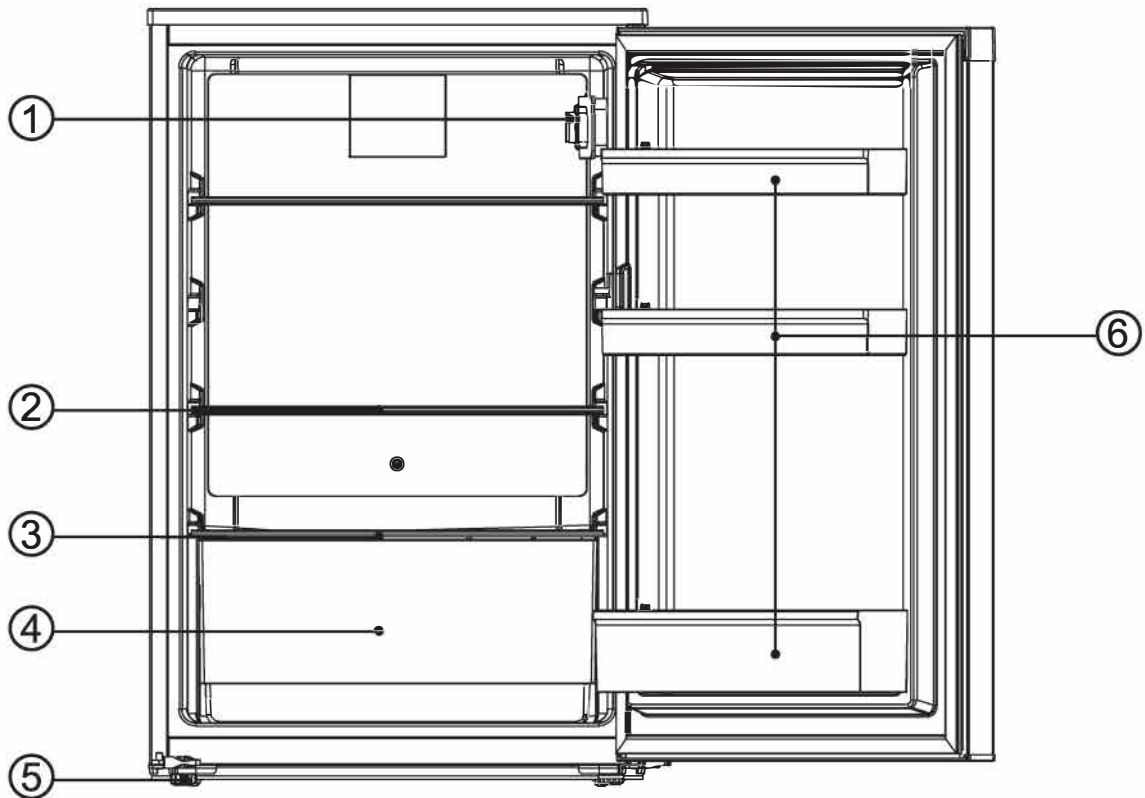

1. Thermostat
2. Shelf
3. Crisper cover
4. Crisper
5. Adjustable front feet
6. Plastic retainings

Note: The glass shelves and the crisper can be removed and inserted for cleaning and storing of food according to the appliance.

TRANSPORT AND HANDING

When transporting, hold the base and lift the refrigerator carefully with an angle inferior to 45 degrees. Never hold the door handle as support. Never place it upside down nor horizontally. Push the refrigerator into place by gently tilting it backwards and then push the appliance on its rear rollers.

INSTALLATION

This refrigerating appliance is not intended to be used as a built-in appliance.

To fix stably, the appliance must be placed on a flat and solid surface. It should not be laid on any soft material.

Choose a location where there is no heat source. Keep the refrigerator away from direct sunlight or other appliance producing heat.

Choose a dry and well-ventilated place where there is no corrosive air.

In order to improve efficiency of the cooling system and save energy, it is necessary to maintain good ventilation around the appliance for the dissipation of heat. For this reason, sufficient clear space should be available around the refrigerator.

The appliance is supplied with two plastic spacers. After installation of these spacers, the appliance cannot be pushed against the wall to maintain proper ventilation. Insert the spacers into the relevant openings on the back of the appliance, then screw the spacers tightly. Place the appliance against a wall with a free distance that not exceeding 75 mm but more than 50mm.

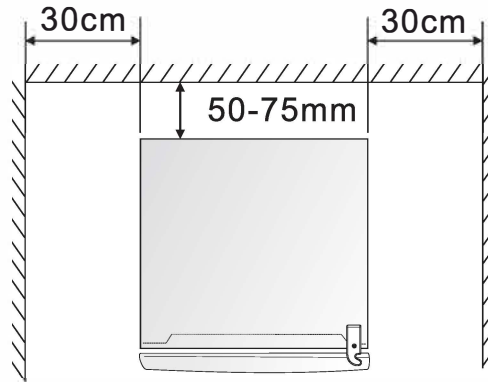

FIRST USE

Before the use of the refrigerator, remove all the packages, including bottom cushion and foam pads and rubber belts in the refrigerator.

Adjust the feet and clean the outside and inside of the refrigerator with warm cloth.

Do not start the refrigerator immediately after vertical placement. Only start it after 2-6 hours standing to ensure its proper operation.

To prevent damage to the power cord and any consequence incidents, the power cord should be not covered by the refrigerator or other objects. Before switching on the refrigerator, please check the voltage range of refrigerator carefully if the same as that of the power supply.

When the refrigerator is first installed, allow it stabilize at normal operating temperatures for 2-3 hours prior to filling it with fresh or frozen foods.

If operation is interrupted, wait for 5 minutes before restarting.

TEST

Clean the parts of the refrigerator with lukewarm water on a soft cloth or with a neutral detergent and with clear water, then wipe them dry.

Notes: Electric parts of the refrigerator can only be wiped by dry cloth.

Turn the thermostat knob on the "3" position and turn on electricity. The compressor begins to work.

Close the door and wait 30 minutes. If the temperature in the fridge compartment has decreased, it shows that the refrigerator system works well. When the refrigerator operates for a period of time, the temperature controller will automatically set the temperature on conditions that the door is not too often opened.

If the above steps are successful, the trial operations are finished. The refrigerator works normally.

TEMPERATURE CONTROL

The fridge is controlled with a temperature control knob located inside it, towards the upper right - hand corner.

Adjust the control knob as desired to suit your individual preference.

0=off setting

1=cold setting

7=coldest setting

- In the off position (0) the appliance does not operate (the cooling system is switched off), but power supply is not interrupted.
- The running time and temperature are affected by where the fridge is located, how often the door is opened and the temperature of the room the fridge is located in.

Set the thermostat knob to "3-4" position for a normal use.

Note: the temperature will impact the storage time of food. Set the temperature as necessary. To higher temperature will accelerate food spoilage and to lower temperature will cause food to freeze. Thus food will be wasted.

STORAGE OF FOOD

This part of the instruction manual will show you the correct way to store food. The glass shelves and crisper can be removed to store food if needed.

Note: Food is not allowed to touch directly all surfaces inside the appliance. It has to be wrapped separately in aluminum sheet, in cellophane or in airtight plastic boxes.

Storing food in the refrigerator compartment

The fridge freezer compartment helps to extend the storage times of fresh perishable foods.

Fresh food care for best results:

- ❑ Store foods that are very fresh and of good quality.
- ❑ Ensure that food is well wrapped or covered before it is stored. This will prevent food from dehydrating, deteriorating in colour or losing taste and will help maintain freshness. It will also prevent odour transfer. Vegetables and fruit need not be wrapped if they are stored in the vegetable container of the fridge compartment.
- ❑ Make sure that strong smelling foods are wrapped or covered and stored away from foods such as butter, milk and cream which can be tainted by strong odours.

- ❑ Cool hot foods down before placing them in the fridge compartment.

Dairy foods and eggs

- ❑ Most pre-packed dairy foods have a recommended 'use by /best before/best by/ date stamped on them. Store them in the fridge compartment and use within the recommended time.
- ❑ Butter can become tainted by strong smelling foods so it is best stored in a sealed container.
- ❑ Eggs should be stored in the fridge compartment.

Red meat

- ❑ Place fresh red meat on a plate and loosely cover with waxed paper, plastic wrap or foil.
- ❑ Store cooked and raw meat on separate plates. This will prevent any juice lost from the raw meat from contaminating the cooked product.

Poultry

- ❑ Fresh whole birds should be rinsed inside and out with cold running water, dried and placed on a plate. Cover loosely with plastic wrap or foil.
- ❑ Poultry pieces should also be stored this way. Whole poultry should never be stuffed until just before cooking, otherwise food poisoning may result.

Fish and seafood

- ❑ Whole fish and fillets should be used on the day of purchase. Until required, refrigerate on a plate loosely covered with plastic wrap, waxed paper or foil.
- ❑ If storing overnight or longer, take particular care to select very fresh fish. Whole fish should be rinsed in cold water to remove loose scales and dirt and then patted dry with paper towels. Place whole fish or fillets in a sealed plastic bag.
- ❑ Keep shellfish chilled at all times. Use within 1-2 days.

Precooked foods and leftovers

- These should be stored in suitable covered containers so that the food will not dry out.
- Keep for only 1-2 days.
- Reheat leftovers only once and until steaming hot.

Vegetable container

- The vegetable container is the optimum storage location for fresh fruit and vegetables.
- Take care not to store the following at temperatures of less than 7°C for long periods: Citrus fruit, melons, aborigines, pineapple, papaya, currettes, passion fruit, cucumber, peppers, tomatoes.
- Undesirable changes will occur at low temperatures such as softening of the flesh, browning and/or accelerated decaying.
- Do not refrigerate avocados (until they are ripe), bananas and mangoes.

Food	Location
Butter, cheese	Upper door rack
Eggs	Door rack
Fruit, vegetables, salad	Crisper
Meat, sausage, cheese, milk	Lower area (lowest shelf / crisper cover)
Dairy products, canned food, cans	Upper area or door rack
Drinks, bottles, tubes	Door rack

This refrigerating appliance is not suitable for freezing foodstuffs.

DEFROSTING

Defrost the refrigerator when the frost is more than 3mm thick. To defrost, put the thermostat control knob to "0", the refrigerator will begin to defrost.

Be sure to keep the drip tray in place.

put the thermostat control knob to "3-4", and the refrigerator starts to work again when defrosting ends.

Empty water from the drip tray after defrosting

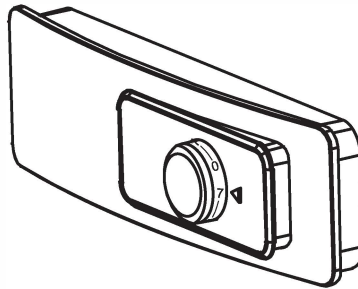

HELPFUL HINTS AND TIPS

We recommend that you follow the tips below to save energy.

- Try to avoid keeping the door open for long periods in order to conserve energy.
- Ensure the appliance is away from any sources of heat(Direct sunlight, electric oven or cooker etc)
- Don't set the temperature colder than necessary.
- Don't store warm food or evaporating liquid in the appliance.
- Place the appliance in a well ventilated, humidity free room. Please refer to Installing your new appliance chapter.
- The "STRUCTURE ILLUSTRATION" shows the correct combination for the drawers, crisper and shelves, do not adjust the combination as this is designed to be the most energy efficient configuration.

Hints for fresh food refrigeration

- Do not place hot food directly into the refrigerator or freezer, the internal temperature will increase resulting in the

compressor having to work harder and will consume more energy.

- Do cover or wrap the food, particularly if it has a strong flavor.
- Place food properly so that air can circulate freely around it.

Hints for refrigerator

- Meat (All Types) Wrap in polythene food: wrap and place on the glass shelf above the vegetable drawer. Always follow food storage times and use by dates suggested by manufacturers.
- Cooked food, cold dishes, etc, They should be covered and may be placed on any shelf.
- Fruit and vegetables: They should be stored in the special drawer provided.
- Butter and cheese: Should be wrapped in airtight foil or plastic film wrap.
- Milk bottles: Should have a lid and be stored in the door racks.

Switching off your appliance

If the appliance needs to be switched off for an extended period, the following steps should be taken prevent mould on the appliance.

1. Remove all food;
2. Remove the power plug from the mains socket;
3. Clean and dry the interior thoroughly;
4. Ensure that all the doors are wedged open slightly to allow air to circulate.

CLEANING AND CARE

For hygienic reasons the appliance (including exterior and interior accessories) should be cleaned regularly at least every two months.

WARNING: The appliance must not be connected to the mains during cleaning. Danger of electrical shock! Before cleaning switch the appliance off and remove the plug from the mains socket.

Exterior cleaning

- To maintain good appearance of your appliance, you should clean it regularly.
- Wipe the display panel with a clean, soft cloth.
- Spray water onto the cleaning cloth instead of spraying directly on the surface of the appliance. This helps ensure an even distribution of moisture to the surface.
- Clean the doors, handles and cabinet surfaces with a mild detergent and then wipe dry with a soft cloth.

Caution!

- Don't use sharp objects as they are likely to scratch the surface.
- Don't use Thinner, Car detergent, Clorox, ethereal oil, abrasive cleansers or organic solvent such as Benzene for cleaning. They may damage the surface of the appliance and may cause fire.

Interior cleaning

You should clean the appliance interior regularly. It will be easier to clean when food stocks are low. Wipe the inside of the fridge with a weak solution of bicarbonate of soda, and then rinse with warm water using a wrung-out sponge or cloth. Wipe completely dry before replacing the shelves and baskets. Thoroughly dry all surfaces and removable parts.

Cleaning the Door seal

Take care to keep door seals clean. Sticky food and drinks can cause seals to stick to the cabinet and tear when you open the door. Wash seal with a mild detergent and warm water. Rinse and dry it thoroughly after cleaning.

Caution!

- Only after the door seals are completely dry should the appliance be powered on.

DOOR REVERSE

Users can change the direction of opening according to one's own needs.

1. Remove the screws behind the top cover with cross head Phillips screwdriver and detach it from the refrigerator.

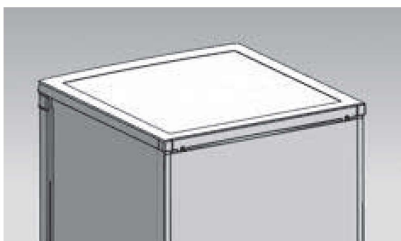

2. Remove the top-hinge fixing screws with cross head screwdriver. Take off the door and put it down with care in a safe location.

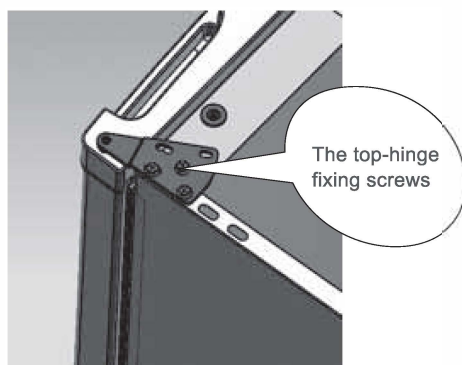

3. Replace the top-hinge, the door limit block and the door bearing bush to the other side.



replace the top-hinge



replace the door bearing bush and the limit block

4. Disassemble the bottom-hinge fixing screws with cross head screwdriver replace and fix the hinge to the other side.

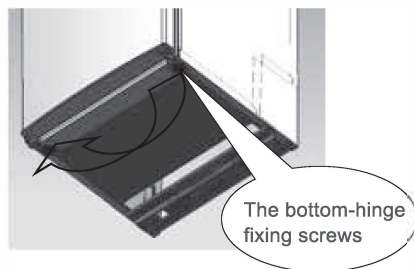

5. Replace the leveler to the other side and adjust it for a proper cabinet.



6. Set the door at right position, fix the top-hinge and then the top cover.

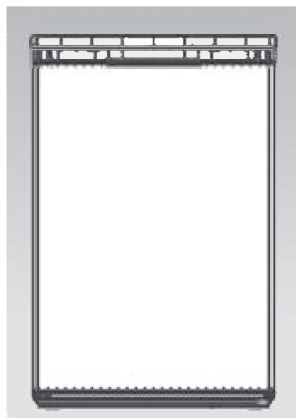

Note:

Ensure the Appliance is unplugged and empty.

Adjust the two leveling feet to their highest position.

We recommend you have someone to assist you.

To take the door off it is necessary to tilt the appliance backward.

The refrigerator inclination angle should be less than 45°.

You should rest the Appliance on something solid e.g.a chair just below the top panel.

Do not lay the Appliance completely flat as this may damage the coolant system.

Reference:	MDAUCL54W
Rated voltage:	220-240V~
Ampere:	0.6A
Rated frequency:	50Hz
Climate class:	N/ST
Refrigerant:	R600a(27g)
Protection against electrical shock:	I
Insulation foam:	CYCLOPENTANE

Climate class:

- Extended temperate(SN): 'this refrigerating appliance is intended to be used at ambient temperatures ranging from 10°C to 32 °C';
- Temperate(N): 'this refrigerating appliance is intended to be used at ambient temperatures ranging from 16 °C to 32 °C';
- Subtropical(ST): 'this refrigerating appliance is intended to be used at ambient temperatures ranging from 16 °C to 38°C';
- Tropical(T): 'this refrigerating appliance is intended to be used at ambient temperatures ranging from 16 °C to 43 °C';

Note:

More data information, please scan the QR code on the energy label.

TROUBLESHOOTING

If your device shows the other symptoms that those described below, please call the service after sale of the shop a retailer.

Symptom	Cause	Solution
The appliance does not work	There is no power supply	Check the plug connecting it others appliance, or verify that the appliance is connected to the plug
	The fuse doesn't work	Replace the fuse
The appliance makes a lot of noise	The appliance is too close to the wall, or is not stable, or the accessories inside the refrigerator are placed in wrong position	Adjust the position of feet to ensure it is level, move the appliance away from the wall, & correctly place the accessories inside the refrigerator.
The appliance doesn't cool enough	The door is too often opened or was left opened for a long time	Close the door and do not open it too frequently
	The refrigerator is too close to the wall	Move the device away from the wall to improve the ventilation
	The refrigerator is too full.	Remove food from the device

Symptom	Cause	Solution
The appliance doesn't cool enough	The temperature is badly adjusted	Turn the knob of regulation of temperature on "3" or more
There are smells in the appliance	Food is out of date inside the refrigerator	Throw away out of date food and wrap others
	The inside of the device at need to be cleaned	Clean the inside of the refrigerator

The following symptoms are not breakdowns:

- The noise of the cooling liquid which circulates in pipes can be heard, it is normal.
- The humidity on the surface outside of the device during the wet seasons is not a problem of the device; you just need to wipe it with a dry soft cloth.
- The compressor and the condenser can warm more during the periods of strong heat.
- The frame of the door is a bit hot; it means that the condenser works to evacuate the humidity of air.

6 Here For You

6.1 After-sales assistance

If you continue to experience problems with your appliance, please call the Montpellier customer service helpline on: **03333 234473**

Please have all your product details available, including the model number, serial number, original sales invoice (clearly showing model number, date of purchase and your retailer's details) before registering a fault.

The service call cannot progress without this information.

Your 2 year Manufacturer's guarantee

THIS DOES NOT AFFECT YOUR STATUTORY RIGHTS.

Your new Montpellier appliance carries a free guarantee which protects you against the cost of repairs during the first 24 months from date of purchase provided that:

Any claim is accompanied by evidence of the model reference, model serial number and proof of purchase, such as a Sales Receipt, showing that the appliance was purchased within the 24 months prior to the date of claim.

What is not covered under the Guarantee

- Any appliance not correctly installed and operated in accordance with the manufacturer's instructions
- Any appliance that is used for anything other than domestic purposes.
- Any defect caused by accident, misuse, unauthorised modification or inexperienced repair.
- Cost of Call-out where a fault cannot be found with the appliance. Cost of Call-out for work covering routine maintenance, such as, but not exclusively, cleaning of filters or defrosting.
- Cost of Call-out for work required to correct the alignment of doors following door reversal procedures carried out by you. Use of the appliance by anyone other than the Householder. Use in any commercial environment.
- Consumable items, such as, but not exclusively, fuses in plugs, bulbs and breakable items which require routine replacement. Repair costs incurred that have not been authorised by Montpellier service and/or carried out by a non-approved Montpellier engineer.

- Montpellier Appliances do not accept claims for consequential loss, rusting, corroding, delivery damage or scratches.

YOUR GUARANTEE IS VALID ONLY IN THE UK & THE REPUBLIC OF IRELAND

To register your appliance simply complete the card in your appliance pack and return it with a stamp affixed or alternatively you can register online at:

montpellier-appliances.com/support

...or by phone, call our warranty registration department on **08081 961 388**

SERVICE HELP - LINE

Should your appliance develop a fault, please call the Montpellier customer service helpline on:

03333 234473

Please remember to have all your product details available, including the model number, serial number, date of purchase and your retailer's details before registering a fault.



Montpellier Domestic Appliances Ltd.

Unit 1, Tewkesbury Retail Park, Northway Lane,
Tewkesbury, Gloucestershire GL20 8JU

www.montpellier-appliances.com



The symbol on the product or on its packaging indicates that this product may not be treated as household waste. Instead it shall be handed over to the applicable collection point for the recycling of electrical and electronic equipment. By ensuring this product is disposed of correctly, you will help prevent potential negative consequences for the environment and human health, which could otherwise be caused by inappropriate waste handling of this product. For more detailed information about recycling of this product, please contact your local city office, your household waste disposal service or the shop where you purchased the product.