

Montpellier

DOMESTIC APPLIANCES

LAUNDRY DISHWASHING COOKING COOLING

Installation & Operating Instructions



700ltr Chest Freezer in White
MDACF700W

Please read these instructions carefully before attempting to install or use this appliance.
We recommend that you keep these instructions in a safe place for future reference.

Welcome

Thank you for choosing this Montpellier appliance.

Your appliance has been designed to provide you with the best combination of style, reliability and performance, to give you years of trouble-free use.

You may be familiar with a similar product, but please take the time to read these instructions carefully before installing or using your appliance to ensure that you get the most from your purchase and keep the manual for future reference.

The design and specifications are subject to change without prior notice for product development.

Montpellier

montpellier-appliances.com

2 YEAR GUARANTEE

PARTS & LABOUR

ACROSS ALL OUR MODELS

Your appliance is covered by a comprehensive two year Parts & Labour Guarantee. In the unlikely event that you experience a problem with your appliance, you can rest assured that you are fully protected against the cost of repairs for the first 24 months. Please note that any claim must be accompanied by the model reference number, serial number and proof of purchase.

To activate your guarantee, you will need your product serial number. This can be found inside your appliance.

NB: Please make sure that you keep a copy of your original sales invoice as this will be needed if any service call is required.





There are three ways to register your Guarantee:

Online: Visit the Support page on our website and complete the online Product Registration form.

www.montpellier-appliances.com

By Post: Simply detach and fill in the form provided, attach a stamp and send it in the post. Don't forget to include your e-mail address so that we can send confirmation through to you.

By Phone: Contact our warranty registration department on **08081 961 388**

Icon	Type	Meaning
	Warning	May Cause Serious Injury
	Risk of Electric Shock	Dangerous Voltage Risk
	Fire	Warning, Risk of Fire/Flammable Materials
	Caution	Risk of Damage/ Important Information

Contents

1.	General Safety Information	4
2.	Electrical Safety	4
3.	Installation	4
4.	Operation	5
5.	Freezing and Storage Guidelines	5
6.	Safe Use	5
7.	Defrosting	5
8.	Cleaning and Maintenance	6
9.	Power Interruption	6
10.	Troubleshooting	6
11.	Transport	6
12.	Disposal	6
13.	Additional Safety Information	7
14.	Climate Range	7
15.	Earthing (Grounding) Requirements	7
16.	Safety Lock	7
17.	Refrigerant Information	8
18.	Product Components	8
19.	Transportation Instructions	9
20.	Handling and Positioning Precautions	9
21.	Installation Instructions	9
22.	Freezer Operation	10
23.	Cleaning and Care	12
24.	Do's and Don'ts	13
25.	Disposal Warnings	14

DEAR CUSTOMER:

Thank you for buying this product. To ensure that you get the best results from this appliance, please take time to read through the simple instructions in this booklet. Please ensure that the packing material is disposed of in accordance with the current environmental requirements. When disposing of any old appliances please contact your local waste disposal department for advice on safe disposal. This appliance must only be used for its intended purpose.

1. General Safety Information



WARNING: It is hazardous for anyone other than authorised service personnel to carry out servicing or repairs that involve removing covers. To avoid the risk of electric shock, do not attempt to repair the appliance yourself.

WARNING: Risk of fire / flammable materials 

- This appliance is designed for domestic use only.
- Do not use the appliance outdoors or in damp or wet environments.
- Installation and repairs must only be carried out by a qualified technician.
- Do not operate the appliance if it is damaged or malfunctioning.

Child Safety

- Children must be supervised at all times when near the appliance.
- Do not allow children to play with the appliance or its packaging.
- If the appliance is fitted with a lock, keep the key out of reach of children to prevent accidental entrapment.

2. Electrical Safety

- The appliance must be connected to a 220–240V, 50Hz earthed mains supply.
- Do not use extension leads or multi-socket adapters.
- Never touch the plug or appliance with wet or damp hands.
- Do not pull the power cable to remove the plug; always hold the plug firmly.
- If the power cable is damaged, it must be replaced by a qualified technician.

3. Installation

Positioning

- Place the appliance on a flat, stable, and level surface.
- Do not install on carpets or soft flooring that may restrict ventilation.
- Ensure adequate space around the appliance for airflow.
- Keep ventilation openings clear and unobstructed at all times.

Environment

- Install in a dry, well-ventilated area.
- Avoid direct sunlight and heat sources such as radiators or ovens.
- Do not install in areas where the temperature may fall below the recommended operating range.

Before First Use

- After installation, leave the appliance upright and switched off for at least 4 hours before connecting to the mains supply.
- Clean the interior using a soft cloth with warm water and a mild detergent, then dry thoroughly.

4. Operation

Switching On

1. Plug the appliance into the mains socket.
2. Turn the thermostat control to the desired setting.
3. Allow sufficient time for the appliance to reach the correct temperature before loading food.

Temperature Control

- Adjust the thermostat to regulate the internal temperature.
- A setting equivalent to approximately -18°C is recommended for normal use.
- Avoid setting the temperature unnecessarily low, as this may increase energy consumption.

Storing Food

- Allow hot or warm food to cool to room temperature before placing it in the freezer.
- Do not overload the appliance, as this will reduce cooling efficiency.
- Ensure all food is properly wrapped or stored in suitable, sealed containers.
- Arrange food to allow air to circulate freely inside the compartment.

5. Freezing and Storage Guidelines

- Do not refreeze food that has completely thawed.
- Clearly label food with the date of freezing.
- Follow recommended storage times for frozen food.
- Do not place carbonated or fizzy drinks in the freezer compartment, as they may burst.

6. Safe Use

- Do not use electrical appliances inside the freezer unless recommended by the manufacturer.
- Do not use mechanical devices (such as heaters or hair dryers) to accelerate the defrosting process.
- Do not store flammable or explosive substances inside the appliance.
- Avoid touching frozen items with wet or damp hands, as this may cause frost burns or skin damage.

7. Defrosting

- Defrost the appliance regularly to maintain efficient operation.

Defrosting Procedure

1. Switch off the appliance and unplug it from the mains supply.
2. Remove all food and store it in a suitable cold environment.
3. Leave the lid open to allow ice to melt naturally.
4. Place a container or absorbent material inside to collect excess water.

5. Once defrosted, clean and dry the interior thoroughly.
6. Reconnect the appliance and allow it to reach the desired temperature before reloading food.

8. Cleaning and Maintenance

General Cleaning

- Always switch off and unplug the appliance before cleaning.
- Use a soft cloth with warm water and a mild detergent.
- Do not use abrasive cleaners, solvents, or sharp tools.

Maintenance

- Clean the interior and exterior surfaces regularly.
- Ensure door seals remain clean and intact to maintain efficiency.
- Check and clean drainage areas (if applicable).

9. Power Interruption

- In the event of a power cut, keep the lid closed as much as possible to maintain the internal temperature.
- Avoid opening the appliance unnecessarily.
- Once power is restored, check the condition of the food before consumption.

10. Troubleshooting

If the appliance is not operating correctly:

- Check that it is properly connected to the mains supply.
- Ensure the thermostat is set correctly.
- Confirm that the lid is fully closed.
- Check that ventilation openings are not blocked.

If the issue persists, contact a qualified service technician.

11. Transport

- Always transport the appliance in an upright position.
- Secure any loose components before moving.
- Use the original packaging where possible to prevent damage.

12. Disposal

- Do not dispose of this appliance with household waste.
- Take it to an authorised recycling facility for electrical appliances.
- Refrigerant and insulation materials must be disposed of safely and in accordance with local regulations.

13. Additional Safety Information

- Do not store flammable gases or liquids, such as aerosol cans or fuel containers, inside the appliance.
- Do not remove items from the freezer with wet hands, as this may cause skin injury.
- Do not attempt to modify or alter the appliance in any way.
- If the appliance is left unused for an extended period, switch it off, clean it thoroughly, and leave the lid open to prevent odours and mould.

14. Climate Range

The climate range of the appliance is indicated on the rating plate. This specifies the ambient temperature (room temperature) at which the appliance will operate most efficiently.

Climate range	Permissible ambient temperature
SN	from +10°C to +32°C
N	from +16°C to +32°C
ST	from +16°C to +38°C
T	from +16°C to +43°C

Note:

Due to variations in ambient temperature, appliance location, and frequency of lid opening, the internal temperature may fluctuate. The temperature setting may need to be adjusted accordingly to maintain optimal performance.

If the power cable is damaged, it must be replaced by the manufacturer, an authorised service agent, or a similarly qualified person to avoid a hazard.



NOTE: If the appliance is used outside of its specified climate range, it may not be able to maintain the correct internal temperature.

15. Earthing (Grounding) Requirements

This appliance must be properly earthed.

- The appliance is fitted with a plug that includes a grounding wire.
- The plug must be connected to a properly installed and earthed socket.

Incorrect use of the plug may result in electric shock.

If you are unsure whether your electrical supply is correctly earthed, consult a qualified electrician.

16. Safety Lock (If Applicable)

If your appliance is fitted with a lock:

- Keep the key out of reach of children.
- Do not store the key near the appliance.

When disposing of an old appliance, remove or disable any locks or latches to prevent children from becoming trapped inside.

17. Refrigerant Information

This appliance uses R600a refrigerant and cyclopentane insulation, which are environmentally friendly and do not damage the ozone layer.

- R600a is a flammable gas.
- The refrigerant system is sealed and should not leak during normal use.

In the event of damage to the refrigeration system:

- Avoid open flames and sources of ignition.
- Ventilate the room immediately by opening windows.
- Do not operate the appliance.

18. Product Components

Model: MDACF500W

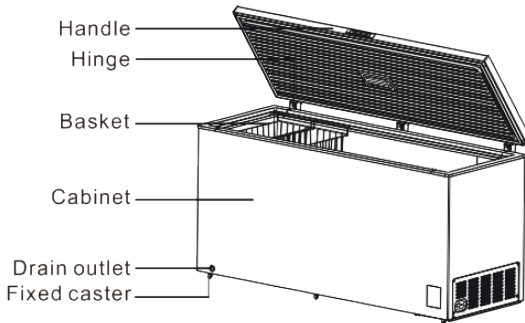

Model: MDACF700W

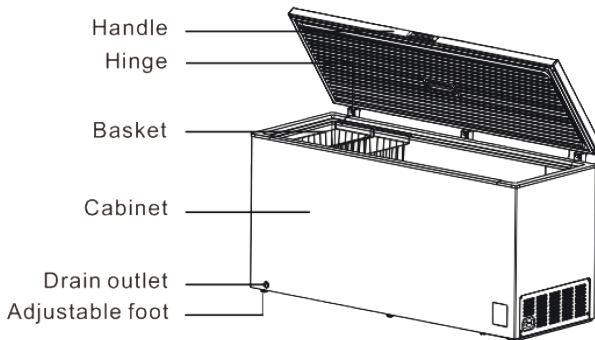

Note:

Due to ongoing product improvements, the appliance may differ slightly from the illustrations and descriptions in this manual. Refer to the actual product for accurate details.



WARNING: Do not touch the interior surfaces of the freezer or frozen food with wet or damp hands, as this may cause frostbite or skin injury.

19. Transportation Instructions

- The appliance must always be transported in an upright position.
- Ensure the original packaging remains intact during transport.

If the appliance has been transported horizontally:

- It must only be laid on its left-hand side (when facing the front).
- Leave the appliance standing upright for at least 4 hours before switching it on.

Failure to follow these instructions may result in damage. The manufacturer accepts no responsibility for damage caused by improper transport.

During Transport

- Protect the appliance from rain, moisture, and adverse weather conditions.

20. Handling and Positioning Precautions

IMPORTANT:

- Take care when moving or cleaning the appliance to avoid contact with the condenser at the rear, as this may cause injury or damage.
- Do not place heavy objects on top of the appliance.
- Do not sit or stand on the appliance.
- Ensure the mains cable is not trapped or damaged during or after installation.
- Do not move the appliance by pulling the lid or handle.
- Take care not to damage flooring, walls, or pipes when positioning the appliance.

Children must not be allowed to play with or tamper with the appliance.

The manufacturer accepts no liability for damage caused by failure to follow these instructions.

21. Installation Instructions

1. If possible, avoid placing the appliance near cookers, radiators, or in direct sunlight, as this will cause the compressor to run for extended periods. If installed next to a heat source or another refrigerator, maintain the minimum clearances shown below:

From Cookers	4" (100 mm)
From Radiators	12" (300 mm)
From Fridges	4" (100 mm)

2. Ensure there is sufficient space around the appliance to allow for adequate air circulation. Ideally, allow at least 10 cm clearance on all sides, as illustrated in the diagram.

3. The appliance should be positioned on a flat, stable surface.

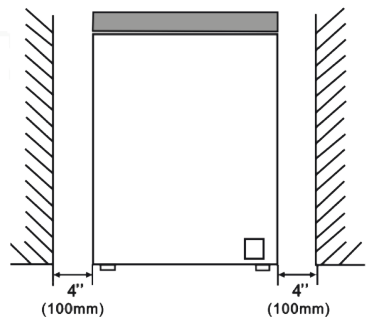

4. This appliance is not suitable for outdoor use.
5. Protect the appliance from moisture. Do not install the freezer in damp or humid environments, as this may cause metal parts to rust. Do not spray water directly onto the appliance, as this may damage the insulation and increase the risk of electrical leakage.
6. Refer to the Cleaning and Care section before first use.
7. If installed in unheated areas such as garages, condensation may form on the outer surfaces during cold weather. This is normal and not a fault. Simply wipe dry with a cloth.

STARTING

Final Checks

Before using your freezer, ensure that:

1. The interior is clean and dry, and air can circulate freely at the rear.
2. The interior has been cleaned as described in the Cleaning and Care section.
3. You may hear noise when the compressor starts. This is normal. The refrigerant circulating within the system may also produce sounds, whether the compressor is running or not.
4. If storing pre-frozen food, wait until the freezer has reached the correct temperature before loading.
5. Do not load the appliance immediately after switching it on. Allow sufficient time for the temperature to stabilise. It is recommended to check using an accurate thermometer.

Important Notes

- In the event of a power failure, do not open the lid. Frozen food should remain safe for up to 20 hours.
- If the power outage lasts longer, check the food and consume immediately or cook and refreeze.
- If the lid is difficult to open shortly after closing, this is due to internal pressure differences. Wait a few minutes for pressure to equalise.

22. Freezer Operation

Display Functions

When the appliance is first powered on, all indicators will illuminate briefly before returning to normal operation.

If no buttons are pressed for 3 minutes, the display will switch off and the controls will lock automatically.

- Press any key to wake the display
- Press and hold the “-” button for 3 seconds to unlock



Temperature Adjustment (Fridge/Freezer Mode)

This appliance can operate as either a fridge or freezer:

- Fridge mode: 8°C to 2°C
- Freezer mode: -12°C to -24°C

Press the "+" or "-" buttons to adjust the temperature. Values change in 1°C increments.

The temperature cycles automatically between ranges when the limits are reached.

Fast Freeze Function

The Fast Freeze function rapidly lowers the temperature to -32°C to preserve food quality.

- Press and hold the "+" button for 3 seconds to activate/deactivate
- The function automatically switches off after 26 hours

Notes:

- The appliance will return to the previous setting after Fast Freeze ends
- If previously in fridge mode, it will default to -18°C

Child Lock

- Activates automatically after 3 minutes of inactivity
- Prevents accidental changes

To unlock:

- Press and hold the "-" button for 3 seconds

Additional Features

- Power Failure Memory: Restores previous settings after power is restored
- Compressor Protection: Delays restart after short power interruptions
- Fault Codes (E0, EP): Contact authorised service personnel
- Over-temperature Alarm (HH): Indicates temperature is too high

Storing Frozen Food

- Follow the manufacturer's instructions on packaging
- Store food as soon as possible after purchase
- Do not exceed "Use By" or "Best Before" dates

Freezing Fresh Food

- Place fresh food near the side walls for faster freezing
- Avoid contact with already frozen food
- Do not exceed maximum capacity
- Freeze food in small portions for best results

Defrosting

Defrost the freezer:

- Twice per year, or
- When frost reaches approximately 7 mm

Steps:

1. Switch off and unplug the appliance
2. Remove food and wrap in insulating material
3. Leave the lid open
4. Place containers of warm water inside to speed up defrosting

Do not use electrical devices (e.g. hair dryers) to defrost.

After defrosting:

- Drain water using the outlet system
- Clean and dry the interior thoroughly
- Switch on Fast Freeze for approximately 3 hours before reloading food

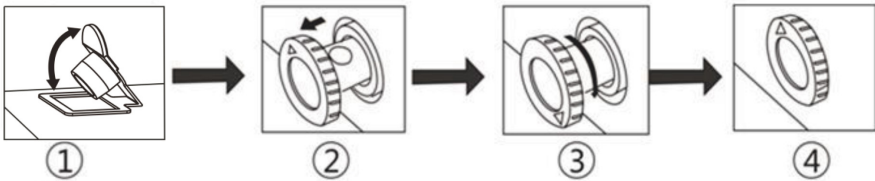

Drainage Instructions

1. Remove the drain plug
2. Pull out the water conduit slightly until the drain hole is visible
3. Rotate the conduit downward to allow water to flow out
4. After draining, return the conduit to its original position

23. Cleaning and Care

- Always switch off and unplug before cleaning
- Use warm water and a mild cleaning solution
- Dry thoroughly after cleaning

Do not use:

- Abrasive cleaners
- Solvents or detergents
- Sharp tools

Additional care:

- Remove ice build-up regularly
- Clean lid seals frequently
- Leave lid slightly open when not in use for long periods

24. Do's and Don'ts**Do's:**

- Defrost regularly
- Keep the lid closed when not in use
- Store food correctly and label it
- Use suitable packaging for freezing

Don't:

- Leave the lid open unnecessarily
- Place hot food inside
- Freeze carbonated drinks
- Use sharp objects to remove ice
- Handle contents with wet hands

Electrical Information

- This appliance must be earthed
- Use a suitable, properly installed socket
- Do not use damaged plugs or cables

If the plug is not suitable:

- It must be safely removed and replaced by a qualified professional

This appliance complies with applicable UK and European safety standards.

Certifications

This product complies with all relevant UK and EU directives and safety regulations.



This marking indicates that this product should not be disposed with other household wastes throughout the EU. To prevent possible harm to the environment or human health from uncontrolled waste disposal, recycle it responsibly to promote the sustainable reuse of material resources. To return your used device, please use the return and collection systems or contact the retailer where the product was purchased. They can take this product for environmental safe recycling.

25. Disposal Warnings

The refrigerant and cyclopentane foaming material used in this appliance are flammable. Therefore, when disposing of the appliance, it must be kept away from fire sources and handled by a suitably qualified waste disposal company. Do not dispose of the appliance by burning, as this may cause environmental damage or pose a safety risk.

When disposing of the appliance, remove the lid, door seals, and internal shelves. Store these parts safely to prevent children from becoming trapped inside the appliance.

Here For You

Here For You

After-sales assistance

If you continue to experience problems with your appliance, please call the Montpellier customer service helpline on: 03333 234473 opt 3

Please have all your product details available, including the model number, serial number, original sales invoice (clearly showing model number, date of purchase and your retailer's details) before registering a fault.

The service call cannot progress without this information.

Your 2 year Manufacturer's guarantee

THIS DOES NOT AFFECT YOUR STATUTORY RIGHTS.

Your new Montpellier appliance carries a free guarantee which protects you against the cost of repairs during the first 24 months from date of purchase provided that:

Any claim is accompanied by evidence of the model reference, model serial number and proof of purchase, such as a Sales Receipt, showing that the appliance was purchased within the 24 months prior to the date of claim.

What is not covered under the Guarantee

- Any appliance not correctly installed and operated in accordance with the manufacturer's instructions
- Any appliance that is used for anything other than domestic purposes.
- Any defect caused by accident, misuse, unauthorised modification or inexpert repair.
- Cost of Call-out where a fault cannot be found with the appliance. Cost of Call-out for work covering routine maintenance, such as, but not exclusively, cleaning of filters or defrosting.

- Cost of Call-out for work required to correct the alignment of doors following door reversal procedures carried out by you. Use of the appliance by anyone other than the Householder. Use in any commercial environment.
- Consumable items, such as, but not exclusively, fuses in plugs, bulbs and breakable items which require routine replacement. Repair costs incurred that have not been authorised by Montpellier service and/or carried out by a non-approved Montpellier engineer.
- Montpellier Appliances do not accept claims for consequential loss, rusting, corroding, delivery damage or scratches.

YOUR GUARANTEE IS VALID ONLY IN THE UK & THE REPUBLIC OF IRELAND

To register your appliance simply complete the card in your appliance pack and return it with a stamp affixed or alternatively you can register online at:

montpellier-appliances.com/support

...or by phone, call our warranty registration department on **08081 961 388**

SERVICE HELP -LINE

Should your appliance develop a fault, please call the Montpellier customer service helpline on:

03333 234473 opt 3

Please remember to have all your product details available, including the model number, serial number, date of purchase and your retailer's details before registering a fault.

Montpellier Domestic Appliances Ltd.

Unit 1, Tewkesbury Retail Park, Northway Lane,
Tewkesbury, Gloucestershire GL20 8UY

www.montpellier-appliances.com



The symbol on the product or on its packaging indicates that this product may not be treated as household waste. Instead it shall be handed over to the applicable collection point for the recycling of electrical and electronic equipment. By ensuring this product is disposed of correctly, you will help prevent potential negative consequences for the environment and human health, which could otherwise be caused by inappropriate waste handling of this product. For more detailed information about recycling of this product, please contact your local city office, your household waste disposal service or the shop where you purchased the product.