

**Series 4, Built-in freezer, 177.2 x 55.8 cm, flat hinge
GIN81VEE0G**



This NoFrost built-in freezer needs no defrosting and features a malfunction warning signal in case of increasing temperature.

- **No Frost:** never defrost again, thanks to perfect protection from ice formation - that saves time and effort.
- **Big Box drawer:** easily stack food containers and store larger items in your freezer.
- **Quiet appliances:** enjoy a calm and relaxing home.
- **Super Freeze function:** prevents the food in your freezer from defrosting.
- **Intelligent Inverter Technology:** ensuring stable temperature control and efficient performance.

Technical Data

Energy Efficiency Class ¹ : E
Average annual energy consumption in kilowatt hour per year (kWh/a): 235 kWh/annum
Sum of volume of frozen compartments: 212 l
Airborne acoustical noise emissions : 35 dB(A) re 1pW
Airborne acoustical noise emission class: B
Thermometer freeze section: Digital
Light: No
Product category: Upright freezer
Built-in / Free-standing: Built-in
Door panel options: Not possible
Frost free system: Fridge and freezer
Height of the appliance: 1772 mm
Width of the appliance: 558 mm
Depth: 545 mm
Required niche size for installation (HxWxD): 1775x560x550 mm
Dimensions of the packed product (HxWxD): 1840x610x640 mm
Net weight: 64.4 kg
Gross weight: 68.7 kg
Fuse protection: 13 A
Frequency: 50 Hz
Length electrical supply cord: 230 cm
Door hinge: Left reversible
Defrost: Automatic
Warning signal / malfunction: Both visual and audible
Door lock: No
Number of drawers/baskets (Stck): 5
Number of freezing flaps (Stck): 2
EAN code: 4242005422098
Brand: Bosch
Product name / Commercial code: GIN81VEE0G
Product category: Upright freezer
Included accessories: 1 x ice cube tray



¹ Scale of Energy Efficiency Classes from A to G

Series 4, Built-in freezer, 177.2 x 55.8 cm, flat hinge GIN81VEEOG

This NoFrost built-in freezer needs no defrosting and features a malfunction warning signal in case of increasing temperature.

-
- No Frost, Built-in tall freezer
 - Fixed hinge

Performance and Consumption

- EU19_EEK_D: E
- Total Volume : 212 l
- Annual Energy Consumption: 235 kWh/a
- EU19_Fast freezer facility_D
- Noise Level : 35 dB , EU19_Noise emission class_D: B

Functions

- Fixed hinge

Design features

- NO_FROST_NEU_BL, never have to defrost ever again
- LED Electronic control
- SuperFreeze function with automatic deactivation
- Freezer malfunction warning signal: optical, acoustical

Food freshness system

- Net Freezer Volume : 212 l
- Net 4* compartment volume : 212 l
- Freezing capacity 24h : 13.8 kg
- Temperature rise time : EU19_Temperature rise time_D: 8 H
- 5 transparent freezer drawers, 2 BigBox
- 2 hinged freezer compartment
- Vario Zone - removable safety glass shelves for extra space!

Dimension and installation

- Dimensions: 177.2 cm H x 55.8 cm W x 54.5 cm D
- Niche Dimensions: 177.5 cm H x 56 cm W x 55 cm D

Key features - Fridge section

- Door left hinged, door reversible
- Climate Class: SN-T
- Length of power cord: 230 cm
- 220 - 240 V

Key features - Freezer section

- ice cube tray

Country Specific Options

- Based on the results of the standard 24-hour test. Actual consumption depends on usage/position of the appliance.

Additional features

Design features

Dimension and installation

Series 4, Built-in freezer, 177.2 x 55.8 cm, flat hinge
GIN81VEE0G

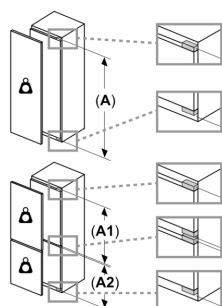
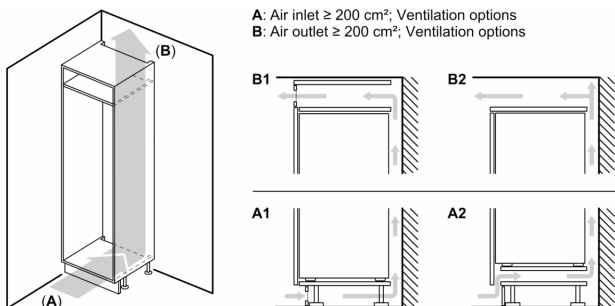

Maximal permissible weight of the unit fronts
 Fitted unit fronts that exceed the permissible weight may cause damage and result in functional impairment of the hinges
 Δ : Weight
 A: Appliance door height including hinges in mm
 B: Undamped hinge, unit front in kg
 C: Damped hinge, unit front in kg
 D: Additional possible load in kg with heavy load kit

A	B	C	D
1500-1750	22	22	B+5 / C+5
720-1400	19	19	
A1	15	19	
A2	15	19	

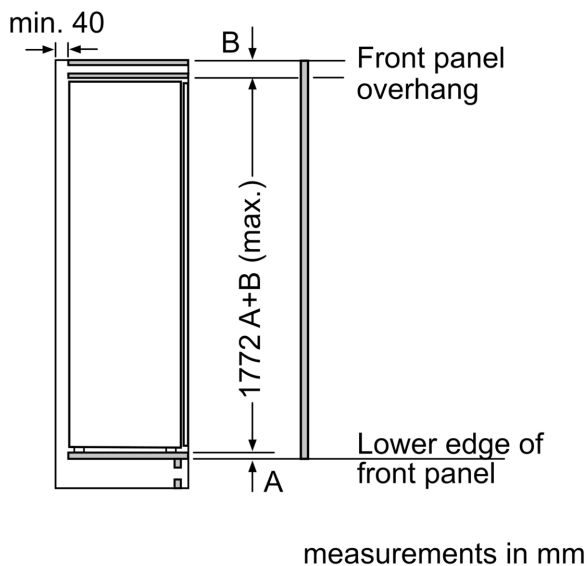
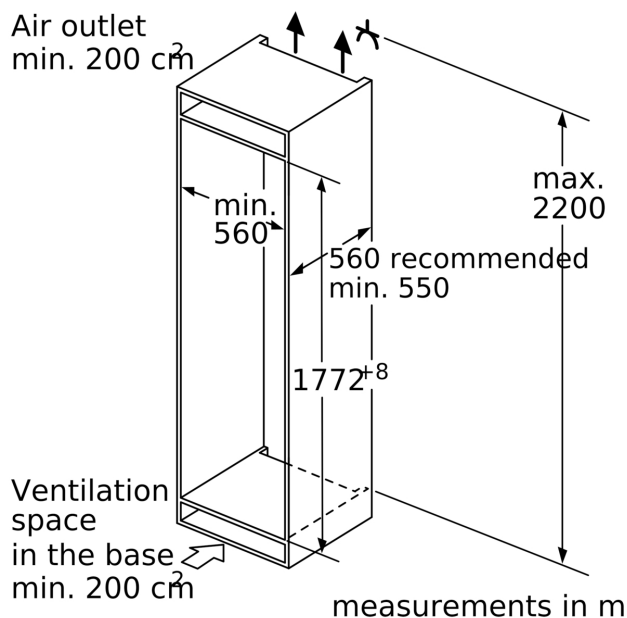
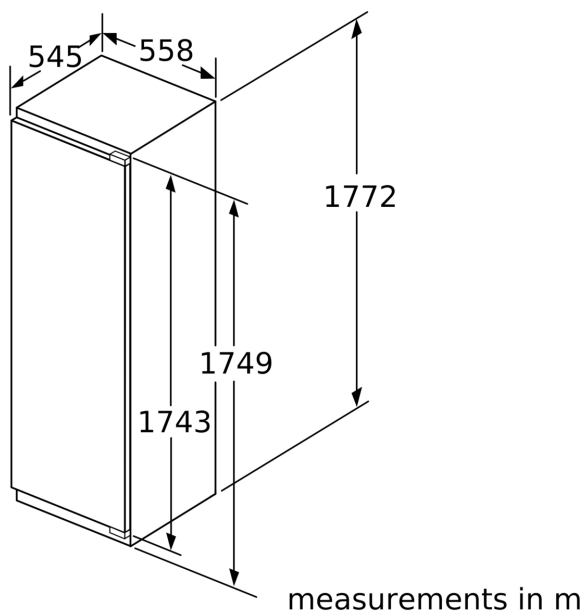

Maximal permissible weight of the unit fronts

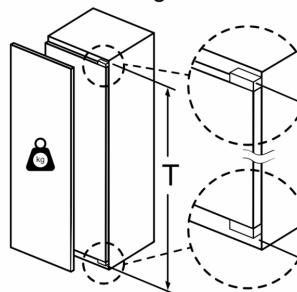

Fitted kitchen unit doors that exceed the permissible weight may cause damage and result in functional impairment of the hinges.

T: Includes height of appliance door Hinges in mm:	undamped hinge, Door in kg:	damped hinge, Door in kg:
1500-1750	22	22

measurements in mm
Recommended gap dimensions for flat hinges

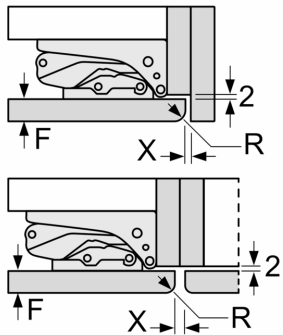

The diagrams show two cross-sections of a flat hinge. The top diagram shows a hinge with a door edge on the left and a cabinet edge on the right. Dimension 'F' is the vertical gap between the door and cabinet. Dimension 'R' is the horizontal gap between the door and cabinet. Dimension 'X' is the horizontal gap between the door and the hinge. A vertical dimension of '2' is shown on the right side of the door. The bottom diagram is similar but shows a different hinge configuration with a vertical dimension of '2' on the right side of the cabinet.

F	R	X
16-19	0-3	2.5
20	0-1	3
	2-3	2.5
21	0-1	3
	2-3	2.5
22	0	4
	1	3.5
	2-3	3

The gap dimensions recommended in the table must be adhered to in order to ensure that appliance doors do not collide with anything when they are opened, and to avoid causing damage to kitchen units.