

**Series 8, Wall-mounted cooker hood,  
90 cm, clear glass black printed,  
Black  
DWK91LT60B**



- **PerfectAir sensor:** automatic extractor control for high performance with low noise.
- **Intensive Setting:** the powerful way to beat intense steam during cooking.
- **EcoSilence Drive™:** the powerful, energy-saving drive for hoods.
- **DirectSelect control:** direct selection of desired settings and light.
- **Easy-to-clean interior:** hidden screws and cables along with rounded edges make cleaning easy.

**Technical Data**

Color chimney: .....	Black
Typology: .....	Wall-mounted
Length electrical supply cord: .....	130 cm
Height of the chimney: .....	420-663/457-750 mm
Height of the appliance: .....	450 mm
Minimum distance above an electric hob: .....	450 mm
Minimum distance above a gas hob: .....	650 mm
Net weight: .....	26.2 kg
Type of control: .....	Electronic
Number of speed settings: .....	3-stage + 2 intensive
Max. air extraction: .....	441 m <sup>3</sup> /h
Boost position output recirculating: .....	944 m <sup>3</sup> /h
Max. air recirculation: .....	437 m <sup>3</sup> /h
Boost position air extraction: .....	1007 m <sup>3</sup> /h
Maximum Air flow: .....	441 m <sup>3</sup> /h
Number of lights: .....	2
Noise level: .....	51 dB(A) re 1pW
Diameter of air outlet: .....	150 mm
Grease filter material: .....	Washable stainless steel
EAN code: .....	4242005391776
Connection rating: .....	250 W
Fuse protection: .....	10 A
Voltage: .....	220-240 V
Frequency: .....	50; 60 Hz
Plug type: .....	GB plug
Installation typology: .....	Wall-mounted

**Optional accessories**

DWZ0BX6K1	Chimney extension 1000 mm
DWZ0BX6L1	Chimney extension 1500 mm
DWZ1BK1B6	Clean Air Plus odor filter (replacement)
DWZ1BK1I6	Clean Air Plus recirculation kit
DWZ1BK1P1	Long Life odor filter (replacement)
DWZ1BK1R1	Long Life recirculation kit (chimless)
DWZ1BK1S1	Long Life recirculation kit
DWZ1BK1V6	Clean Air Plus recirc. kit (chimless)



## Series 8, Wall-mounted cooker hood, 90 cm, clear glass black printed, Black DWK91LT60B

### Design:

- angled glass design
- wall-mounted
- Black glass
- Suitable for ducted or recirculating operation
- In recirculation operation chimless use possible
- For recirculation operation Clean Air Plus recirculation kit (accessory) or Longlife recirculation kit (accessory) needed.

### Core Features:

- Efficient BLDC technology
- 2 PC, LED, 3W, with Colour temperature adjustable
- Softlight dimmer function : the lighting elements switch on and off smoothly.
- Dimmer function : the brightness of the lighting elements can be adjusted.
- Colour Temperature: 3500 K
- Light Intensity: 422 lux
- Powerboost position: Hood can be opened to a defined extraction boost position in order to increase the catch rate of particularly strong cooking smells and large amounts of steam.
- 2 capture areas: front side and bottom side
- 3 metal grease filter(s).

### Comfort Features:

- PerfectAir sensor: Automatic Sensor-based performance control for best results
- 3 power levels and 2 intensive settings
- Automatic reset from intensive to normal setting after 6 min
- Saturation indicator for metal and charcoal filter
- after run automatic: 10 minutes

### Digital Features:

- Home Connect: operate, monitor and set preferences of your hood via smartphone or tablet (only in countries where Home Connect service is available)
- Hob based hood control: automatically activates the hood when cooking, thanks to the WiFi connection of hood and suitable hob.
- fully automatic Hood
- Voice Control enabled via popular voice assistants (only in countries where this service is available)
- Performance Profiles: choose between standard, performance or silence profiles to increase the extraction rate or reduce the fan noise via Home Connect App
- Favourite Button: directly access favourite functions with a configurable button (available with connected Home Connect account).
- Smart home trigger, via Favourite button (available with connected Home Connect account): open up the smart universe from your hood (partner service required).
- LED light with adjustable light temperature: Allows you to adapt the light temperature to your personal needs via Home Connect App
- Interval function: available via Home Connect App
- The Home Connect functionality can be extended by integrating

numerous applications from external cooperation partners (partnerships)

- Updateable appliance (available with connected Home Connect account): keep appliance always up to date with latest status of software.

### Cleaning Comfort:

- Extremely large opening angle for an easy filter accessibility and easy cleaning.
- Easy to clean smooth surfaces and materials.
- easy to clean Inner frame
- Removable metal grease filters dishwasher-safe

### Performance Exhaust:

- According to EN 61591 and EN/ IEC 60704-2-13 your appliance can achieve the following values in exhaust mode: Speed 1: extraction rate 228 m<sup>3</sup>/h ; noise level 35 dB (A) re1pW Speed 2: extraction rate 325 m<sup>3</sup>/h ; noise level 43 dB (A) re1pW Speed 3: extraction rate 441 m<sup>3</sup>/h ; noise level 51 dB (A) re1pW Intensive 1: extraction rate 753 m<sup>3</sup>/h ; noise level 65 dB (A) re1pW Intensive 2: extraction rate 1007 m<sup>3</sup>/h; noise level 70 dB (A) re1pW
- Energy Efficiency Class: A+ (at a range of energy efficiency classes from A+++ to D)
- Average Energy Consumption: 39.1 kWh/year\*
- Blower Efficiency Class: A\*
- Lighting Efficiency Class: A\*
- Grease Filtering Efficiency Class: C\*

### Performance Recirculation:

- According to EN 61591 and EN/ IEC 60704-2-13 your appliance can achieve the following values in recirculation mode with Clean Air plus recirculation kit, for installation with chimney (available as optional accessory): Speed 1: extraction rate 211 m<sup>3</sup>/h ; noise level 42 dB (A) re1pW Speed 2: extraction rate 315 m<sup>3</sup>/h ; noise level 51 dB (A) re1pW Speed 3: extraction rate 435 m<sup>3</sup>/h ; noise level 59 dB (A) re1pW Intensive Speed 1: extraction rate 752 m<sup>3</sup>/h ; noise level 72 dB (A) re1pW Intensive Speed 2: extraction rate 964 m<sup>3</sup>/h ; noise level 78 dB (A) re1pW

### Technical Information and Sustainability:

- Consumption data:
- Power rating: 250 W
- Voltage: Nominal voltage: 220 - 240 V
- Sustainability:
- Made in Germany: produced at a CO<sub>2</sub> neutral production site
- Environmentally friendly packaging
- Most efficient blower technology available on the market
- Available odour filter as regenerative Long Life filter with 10 years lifetime
- PerfectAir sensor: Sensor-based performance control for best results with minimum energy consumption.

### Planning and Installation Information:

- Dimensions exhaust air (HxWxD): 855-1098 x 890 x 447 mm
- Dimensions recirculating (HxWxD): 892-1185 x 890 x 447 mm
- Dimensions recirculating installation, chimless (HxWxD): 471mm x 890 mm x 447 mm
- simple and weight-reduced mounting thanks to the new easy installation system
- Diameter pipe Ø 150 mm (Ø 150 mm enclosed)
- Electrical cable length 1.3 m



test5

**Series 8, Wall-mounted cooker hood,  
90 cm, clear glass black printed,  
Black  
DWK91LT60B**

Measurements in mm  
**Appliance in exhaust air mode**

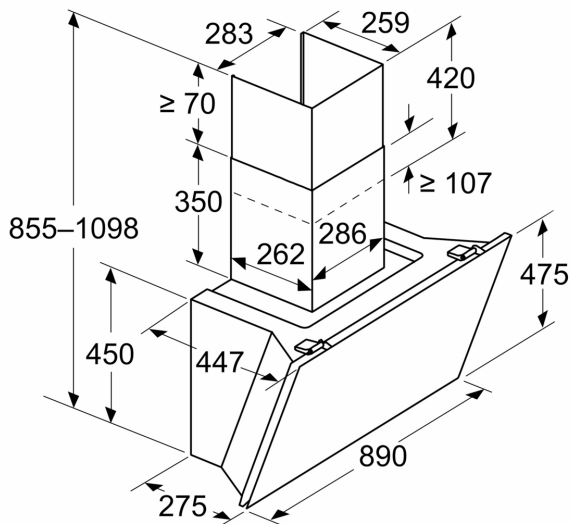

Measurements in mm  
**Appliance in circulated air mode**

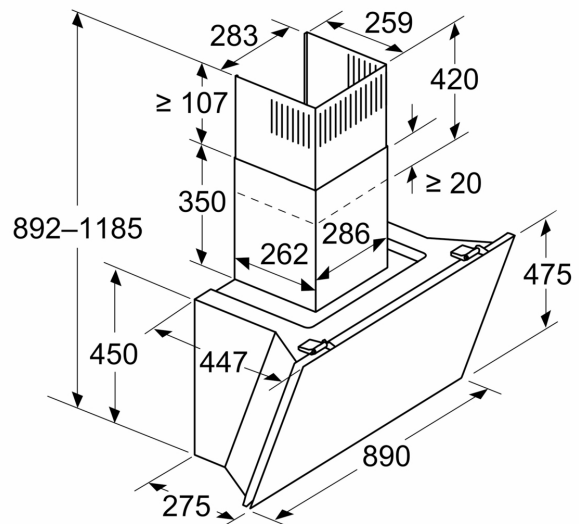

Measurements in mm  
**Appliance in circulated air mode without duct**

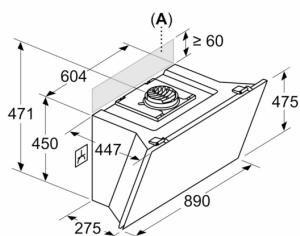

Socket can be fitted to the side of or above the appliance

A: Socket only outside the marked area

Measurements in mm

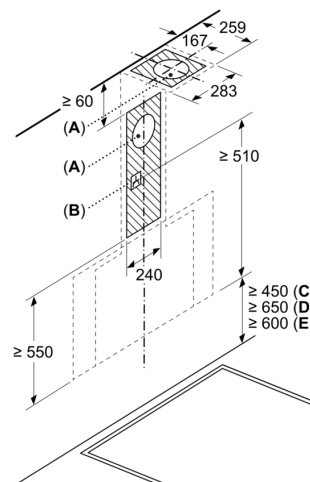

- A: Exhaust-air outlet
- B: Socket
- C: Electric
- D: Gas - from upper edge of pan support
- E: Electric - for Australia and New Zealand

Measurements in mm  
Wall installation with chimney

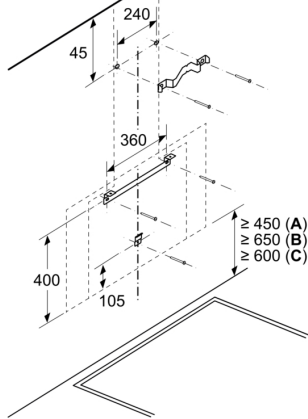

- A: Electric
- B: Gas - from upper edge of pan support
- C: Electric - for Australia and New Zealand

Measurements in mm

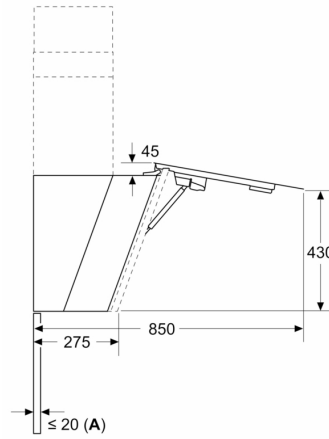

- A: Max. back wall thickness

Measurements in mm

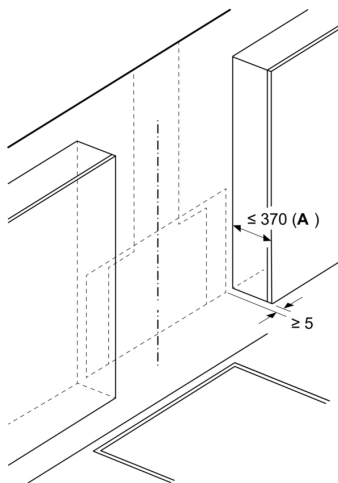

- A: Max. depth of side upper cabinets (incl. door) due to installation of glass plate

Appliance must be installed before upper cabinets, if these are deeper than 370 mm