



TEKNIX

Instruction manual

Built-in Fan Oven

BITK63ESB

BITK63ESX



You'll soon be enjoying your new Built-in Oven

It all begins here, with your instructions. Don't worry, there's nothing too technical coming up. Just simple, step-by-step guidance to get you up and running quickly. Sound good? Then let's get started.

Contents

1 Safety information

Safety information 6

2 Getting to know your Built-in Oven

Ready? Let's begin 9

Accessories 10

3 Installing your Built-in Oven

Cabinet installation 12

Electrical Connection 13

4 Using your Built-in Oven

Controls 15

Oven functions Programming 16

General oven and Cooking tips 17

5 Care and Maintenance

Cleaning 21

Replacing the lamps 22

Removing the Inner pane of glass & cleaning the glass 22

Technical specification 23

6 Product support

Troubleshooting 25

Declaration of conformance to product standards 26

Disposal 26

Warranty 27

Safety information 1



Safety information

Important - Please read these instructions fully before installing or operating

INSTALLATION WARNINGS

IMPORTANT: Prior to Installation ensure that the local supply conditions (electricity voltage and frequency are compatible with the requirements of your built-in oven.

IMPORTANT: Carefully unpack and examine the appliance for any damage. If you think there is a defect, do not use the appliance and contact Product Support on 01759 487823. Packaging materials should be collected together and disposed of immediately as they may be harmful to children.

IMPORTANT: Keep the electrical cable (not supplied of your built-in oven away from the hot areas of your appliance, do not let the cable touch the appliance. Keep the cable away from sharp edges and heated surfaces.

IMPORTANT: Ensure that the electric supply cable is not trapped or damaged during installation.

IMPORTANT: In the event that the cable connecting your built-in oven becomes damaged, it must be replaced by a suitably qualified person. This cable must not be replaced by an unauthorised person.

IMPORTANT: Protect your built-in oven against atmospheric effects. Do not expose your oven to effects such as sun, rain, snow etc.

IMPORTANT: The materials surrounding the appliance (cabinets) must be able to withstand a minimum temperature of 100°C.

IMPORTANT: When using your oven for the first time your built-in oven may give off an

unusual odour from the heating elements and insulation materials. This is normal for cooking appliances. To eliminate this odour run the oven at 250 degrees for 40-60 mins with the oven empty.

WARNING: Before obtaining access to terminals, all supply circuits must be disconnected.

DURING USAGE

IMPORTANT: This appliance can be used by children aged from 8 years and above and persons with reduced physical, sensory or mental capabilities or lack of experience and knowledge if they have been given supervision or instruction concerning use of the appliance in a safe way and understand the hazards involved. Children shall not play with the appliance. Cleaning and user maintenance shall not be made by children without supervision.

WARNING: The appliance and its accessible parts become hot during use. Care should be taken to avoid touching heating elements. Children less than 8 years of age shall be kept away unless continuously supervised.

WARNING: NEVER try to extinguish a cooking fire with water. Instead switch off the appliance and cover flame e.g. with a lid or a fire blanket.

CAUTION: Do not allow children in the kitchen when cooking or after, as the parts may still be hot. Many parts of the oven will become hot and present a considerable hazard to children.

CAUTION: When the oven is hot never touch the oven glass by hand or with tools.



Safety information

Important - Please read these instructions fully before installing or operating

CAUTION: Before starting to use your appliance, ensure curtains, paper or flammable items are kept away from your appliance. Do not keep flammable materials inside of or around your oven.

CAUTION: Take care when closing the oven door that there is nothing obstructing it from closing as this may break the glass door.

IMPORTANT: When using the grill the oven door must be kept closed.

IMPORTANT: Make sure the oven control knobs are all in the off position when not in use.

IMPORTANT: If you do not intend to use your built-in oven for a long period of time turn off the electric supply to the oven.

GENERAL SAFETY WARNINGS

IMPORTANT: This appliance has been designed for non-professional, domestic use only. Do not use this oven for commercial use or any other application e.g. room heating.

WARNING: Danger of fire: do not store flammable items on or near the cooking surfaces or inside the oven.

IMPORTANT: Do not try to lift or move this appliance by pulling on the door handle.

WARNING: Ensure that the appliance is switched off before replacing the lamp to avoid the possibility of electric shock.

IMPORTANT: Your appliance is produced in accordance with all applicable local and international standards and regulations.

IMPORTANT: Maintenance and repair work must only be performed by authorised service technicians. Installation and repair work that is carried out by unauthorised technicians is dangerous and could invalidate your guarantee.

IMPORTANT: When the door of the oven is open, do not hang or lean anything on it. You may unbalance your appliance or damage the door or door hinges.

IMPORTANT: Do not hang towels, dishcloths or clothes from the built-in oven or its handles.

CLEANING AND MAINTENANCE

IMPORTANT: Always turn the appliance off before operations such as cleaning or maintenance. You can do this by switching the built-in oven off using cooker isolation switch.

IMPORTANT: Do not remove the control knobs to clean the control panel.

WARNING: Do not use harsh abrasive cleaners or sharp metal scrapers to clean the oven door glass since they can scratch the surface, which may result in shattering of the glass.

TO MAINTAIN THE EFFICIENCY AND SAFETY

OF YOUR APPLIANCE, WE RECOMMEND YOU ALWAYS USE OUR AUTHORISED SERVICE AGENTS AND ORIGINAL SPARE PARTS.

FOR ASSISTANCE CALL PRODUCT SUPPORT 01759 487823.

Getting to know your Built-in Oven 2

Getting to know your Built-in Oven

You'll be up and running in no time

Ready? Let's begin...

Please read these instructions carefully. They contain important information which will help you get the best from your Built-in Oven and ensure safe and correct installation and operation.

If you require any further assistance, our technical experts are happy to help. For full details, refer to the product support section at the end of these instructions.

Getting to know your Built-in Oven

You'll be up and running in no time

Built-in Oven Accessories

1. 1 x Baking tray
2. 1 x Chrome shelves
3. 1 x Grill insert
4. 1 x User Manual
5. 1 x Fixing kit

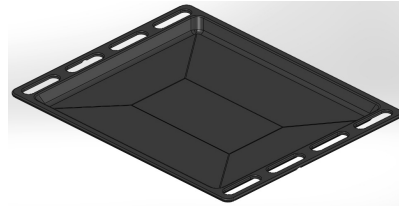

1

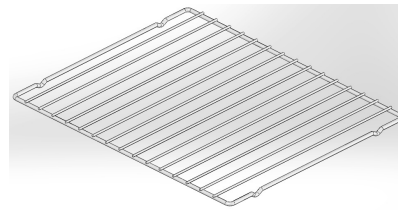

2

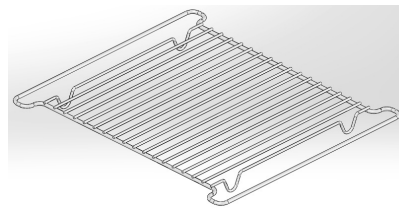

3

Tools needed for installation

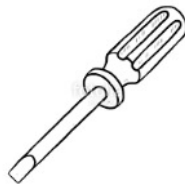

Cross head screwdriver



Electric drill



Pencil

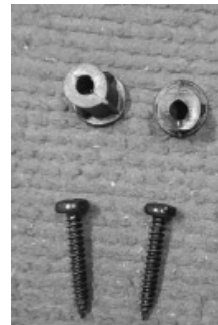

5

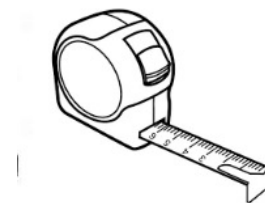

Tape measure

Installing your Built-in Oven 3

Installing your Built-in Oven

Bringing it all together

Installation

This appliance should be installed by a competent person or qualified electrician in accordance with the regulations in force (All relevant British Standard/ Codes of Practice/relevant Building/IET regulations) and in a well ventilated space. Please read instructions before installing and using this appliance.

Important: - The power supply to the appliance must be switched off before any adjustments or maintenance work is carried out.

Installation of Built-in Ovens

In order to ensure that the built-in appliance functions properly, the cabinet containing it must be appropriate. The figure below gives the dimensions of the cut-out for installation under the counter or in a wall cabinet unit.

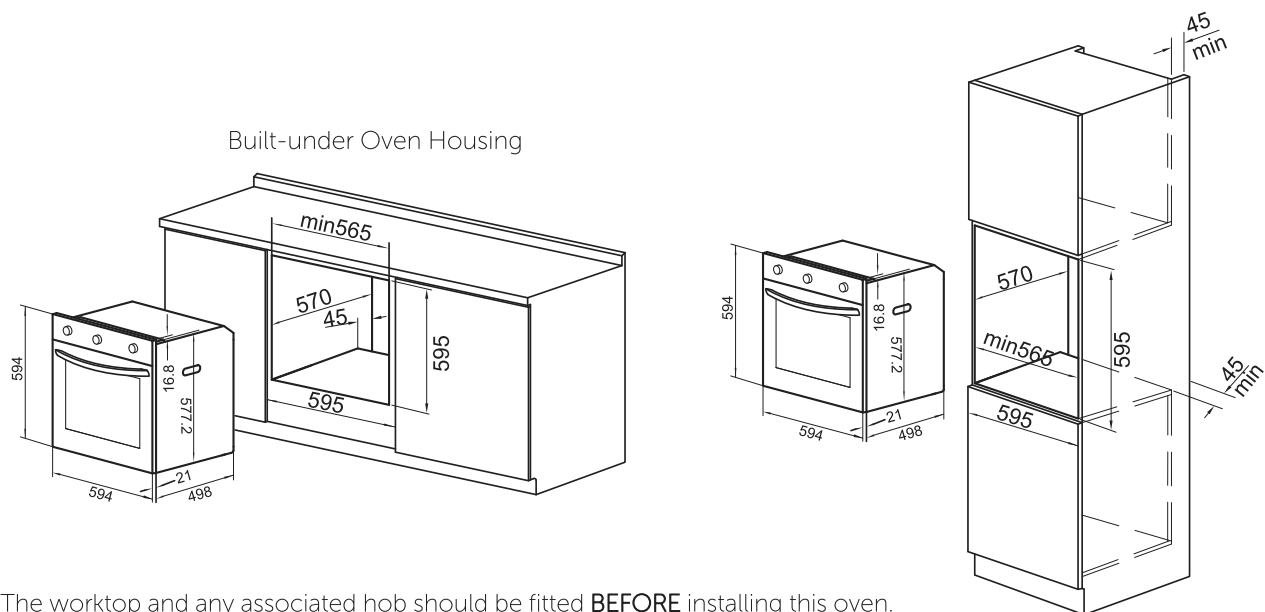

The worktop and any associated hob should be fitted **BEFORE** installing this oven.

It is recommended that if installing a built-in oven directly under the hob then there should be a minimum air gap of 20 mm between the oven and the bottom of the hob. Failure to maintain a suitable clearance may impair the performance of the hob.

Ensure that air can flow freely around the housing area. If the oven is being installed into a fully enclosed built-under oven housing unit it may be necessary to cut a small slot in the top of the plinth fitted under the unit. Cut a section in the centre of the plinth that is 400mm wide and 45mm deep to allow air to pass under the unit. Alternatively cut a section 400 x 450mm in the base of the centre of the plinth.

Failure to allow adequate ventilation to the appliance may result in overheating or damage to adjacent units and could invalidate the guarantee. Surfaces of furniture and walls adjacent to the appliance should be heat, splash and steam resistant. All cabinet doors must be at least 4mm from the oven at all points.

Certain types of vinyl or laminate kitchen furniture are particularly prone to heat damage and discolouration.

When placing the oven in the housing, do not use the oven door or handle as a lever for lifting the oven as damage may result. When you open the oven door, you will see 2 screw holes on either side of the oven where you fix the oven to the cabinetry.

The oven should then be secured to the housing by fitting screw provided into these holes.

Installing your Built-in Oven

Bringing it all together

Provision for Ventilation

The appliance housing used must provide adequate ventilation.

For built-in installation, a minimum ventilation space of 85 – 90mm 40mm must exist between the rear of the appliance and the back of the housing or an adjacent wall.

If a tall housing is to be installed flush with the ceiling, a 20cm² ventilation cut-out must be provided at the top of the housing.

Electrical Connection

This appliance must be installed by a qualified electrician to comply with the relevant Institution of Engineering and Technology (I.E.T.regulations and also the local electricity supply company requirements.

This product comes fitted with a BS plug and cord.
Ensure the cable route avoids the risk of trapping or touching hot surfaces.

The oven is supplied with a BS plug and cord. In the case of replacement of cable or repair, please call our experts on 01759 487823.

Installing Shelves

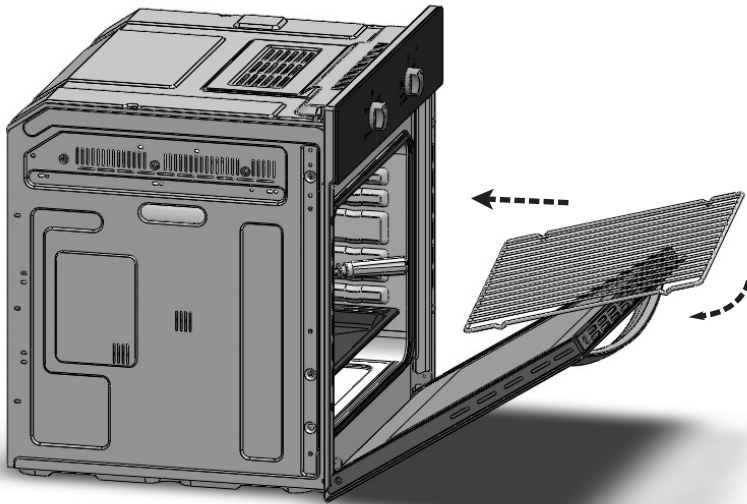

Using your Built-in Oven

4

Using your Built-in Oven

Getting started

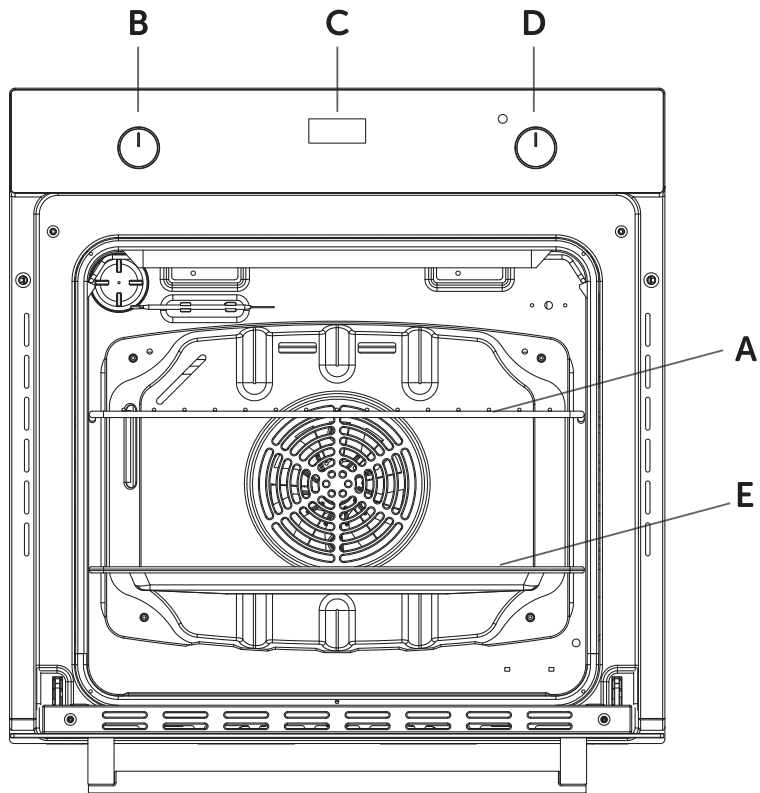

- A. Chrome wire shelf
- B. 5 Function mode control knob
- C. Programmable timer
- D. Temperature control knob
- E. Baking tray

Using your Built-in Oven

Getting the most from your appliance

Oven functions



Oven Light



Grill



Fan Grill



Fan oven



Defrost

Oven light-The oven light will operate on all oven functions.

Grill-This is the top heating element. The extremely high and direct temperature of the grill makes it possible to brown the surface of meats and roasts while locking the juices in to keep them tender. The grill is also highly recommended for dishes that require a high temperature on the surface: beef steaks, veal, rib steak, fillets, hamburgers etc.

Fan grill-This function uses the fan to circulate the heat from the grill element around the food. This helps prevent food from burning on the surface, allowing the heat to penetrate right into the food. Excellent results are achieved with kebabs made with meats and vegetables, sausages, ribs lamb chops, chicken in a spicy sauce, quail, pork chops, etc.

Conventional heat-This function uses the top and bottom heating elements. Natural convection creates a perfect cooking zone in the centre of the oven, ideal for dark fruit cakes and pastries or a joints of meat.

Fan oven-When set to Fan oven mode, the fan element and the fan operate providing a delicate heat distributed uniformly throughout the oven. This mode is ideal for baking and cooking delicate foods on multiple shelves, especially cakes that Swiss rolls and small portions of vegetables, etc.

Defrost - When set to 'Defrost' mode, the fan located at the back of the oven circulates room temperature air around the food. This is recommended for the defrosting of all types of food, but in particular for delicate types of food which do not require heat, for example: ice cream cakes, cream or custard desserts, fruit cakes, etc.

By using 'Defrost' mode, the defrosting time is approximately halved.

Using your appliance for the first time

The first time you use your appliance, we recommend that you set the temperature setting to the 250 degrees. Set the cooking mode selection knob to fan assisted mode and leave the oven on for 40-60 minutes with nothing in it and the oven door shut. Then, open the oven door and allow the oven to cool. Any odour that may be detected during this initial use is due to the evaporation of substances used to protect the oven during storage.

Using your Freestanding Cooker

Getting the most from your appliance

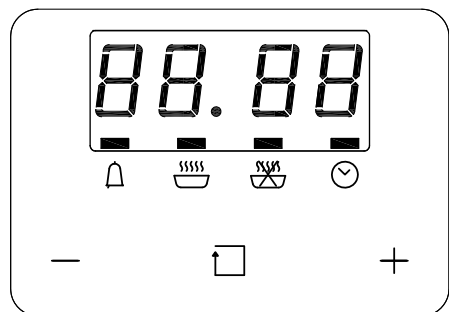

Programmable Timer

Clock setting

Set the time before you start using the oven.

When connecting the appliance to the electrical power supply for the first time or after a mains power failure, the " ⌚ " symbol will flash.

Press the "+" or "-" button to set the time. After approximately five seconds the indicator light will stop flashing and the display will show the set time.

To change the time subsequently, press the function selection button " ↱ " until the " ⌚ " symbol starts flashing, then press the "+" or "-" button to set the correct time.

Manual cooking procedure (without using the cooking programmer)

To switch on and use the oven in manual mode (disabling the cooking programmer), simply set the cooking mode selection knob to the required position and then set the temperature on the thermostat knob.

To switch off the oven set both the knobs to the top position "0".

Timer cooking procedure

-Cooking time setting

1A - Set the cooking duration (max 10 hours). Press the function selection button " ↱ " repeatedly until the " 🍲 " symbol starts flashing, then press the "+" or "-" button to set the cooking duration;

2A - Having no further settings in a few seconds, the " 🍲 " symbol will stop flashing and turn always lighted, immediately cooking is started. When cooking is ended the oven will automatically switch off, the " 🍲 " symbol will flash and the alarm will sound. To mute the alarm press any key; after one minute the alarm will switch off automatically.

- Cooking end time setting

1B - Set the cooking end time (current clock time + up 10:00 max). Press the function selection button " ↱ " repeatedly until the " 🕒 " symbol starts flashing, then press the "+" or "-" button to set the cooking end time.



2B - Having no further settings in a few seconds, the " 🕒 " symbol will stop flashing and turn always lighted, immediately cooking is started. When the set time is reached the oven will switch off automatically, the " 🕒 " symbol will flash and the alarm will sound. To mute the alarm press any key; after one minute the alarm will switch off automatically.



Using your Freestanding Cooker

Getting the most from your appliance

Timer setting

The longest settable time interval is 23 hours and 59 minutes.

1 - To set the time, press the function selection button "  " repeatedly until the "  " symbol starts flashing, then press the "+" or "-" button to set the required time, which will be shown on the display;

2 - After having set the time (hours, minutes) the "  " symbol will flash and the countdown will start. Once the set time has been reached the "  " symbol will flash and the alarm will sound. To mute the alarm press any key; after one minute the alarm will switch off automatically.

The oven light

Set cooking mode selection knob to  symbol to switch on the oven light/s. The oven light/s stay on when the oven is operating.

General oven and cooking tips

General Oven Tips

The wire shelves should always be pushed firmly to the back of the oven.

Baking trays with food cooking on them should be placed level with the front edge of the oven's wire shelves. Other containers should be placed centrally. Keep all trays and containers away from the back of the oven, as over-browning of the food may occur.

For even browning, the maximum recommended size of a baking tray is 340 mm (13½") by 340 mm (13½").

When the oven is on, do not leave the door open for longer than necessary, otherwise the knobs may get very hot.

Always leave 1-2cm between dishes on the same shelf. This allows the heat to circulate freely around them.

To reduce fat splashing when you add vegetables to hot fat around a roast, dry them thoroughly or brush lightly with cooking oil.

Where dishes may boil and spill over during cooking, place them on a baking tray.

Using the Grill

This multi-function oven has 2 different grilling modes.

Use the 'Grill' mode with the oven door closed, place the food on the center of the grill pan, insert and fit the grill pan on either the 3rd or 4th shelf from the bottom. Note: only the central part of the top heating element operates for grilling.

When using 'Grill' mode, we recommend you set the temperature to the highest setting. However, this does not mean you cannot use lower temperatures, simply adjust the knob to the desired temperature.

Use 'Fan assisted grill' mode with the oven door closed. This mode is very useful for grilling foods rapidly, as the distribution of heat by the fan makes it possible not only to brown the surface, but also to cook the bottom of the food. It can also be used for browning foods at the end of the cooking process, such as adding that gratin finish to pasta bakes.

When using 'Fan assisted grill' mode, place the food on the 2nd or 3rd oven shelf from the bottom, then place a dripping-pan on the 1st rack from the bottom to prevent fat and grease from dripping onto the oven floor. We recommend you set the temperature to 200°C, as it is the most efficient temperature for 'Fan assisted grill' mode. However, this does not mean you cannot use lower temperatures, simply adjust the knob to the desired temperature.

IMPORTANT: When using any of the oven functions you must cook with the oven door closed including when using a grill function.

General oven and cooking tips

Baking cakes

When baking cakes, always place them in a preheated oven. Make sure you wait until the oven has been preheated thoroughly (the indicator light will turn off). To prevent heat loss and the cake from dropping, do not open the oven door during baking.

In general...

... if pastry is too dry

Increase the temperature by 10°C and reduce the cooking time.

... if pastry has dropped

Use less liquid or lower the temperature by 10°C.

... if pastry is too dark on top

Place it on a lower shelf, lower the temperature, and increase the cooking time.

... if cooked well on the inside but sticky on the outside

Use less liquid, lower the temperature, and increase the cooking time.

... if the pastry sticks to the pan

Grease the pan well and sprinkle it with a dusting of flour or use greaseproof paper.

... if I used multi shelf cooking and one shelf is more cooked

Use a lower temperature setting next time. It is not necessary to remove the food from all the racks at the same time.

Cooking pizza -Suggested Function

For best results when cooking pizza:

Preheat the oven for at least 10 minutes.

Use a light aluminum pizza pan, placing it on the shelf supplied with the oven. Don't use the dripping pan since this will extend the cooking time, making it difficult to get a crispy crust.

Do not open the oven door frequently while the pizza is cooking;

If the pizza has a lot of toppings (three or four), we recommend you add the mozzarella cheese on top halfway through the cooking process.

For best results, only use one shelf at a time, but if you want to cook on two shelves, use the 2nd and 4th racks from the bottom with a temperature of 220°C and swap them halfway through cooking.

General oven and cooking tips

Cooking fish and meat-Suggested cooking function



When cooking white meat, fowl and fish, use a temperature setting from 180°C to 200°C.

For red meat that you want well done on the outside while tender and juicy in the inside, it is best to start with a high temperature setting (200°C-220°C) for a short time, then turn the oven down afterwards.

In general, the larger the roast, the lower the temperature setting. Place the meat on the centre of the shelf and place the dripping pan beneath it to catch the fat.

Make sure that the shelf is inserted so that it is in the centre of the oven. If you would like to increase the amount of heat from below, use a lower shelf height. For savoury roasts (especially duck and wild game), dress the meat with lard or bacon on the top.

Care and maintenance 5

Care and maintenance

Looking after your appliance

Cleaning

WARNING! Isolate the power supply to the appliance and make sure that the oven is cool.

Before cleaning your oven or performing maintenance switch off the power and make sure that the cooking mode selection knob and the cooking temperature selection knob are set to 'OFF'. To extend the life of your oven, it must be cleaned frequently.

The inside of the oven should preferably be cleaned immediately after use, when it is still warm (but not hot), with warm water and soap.

The soap should be rinsed away and the interior dried thoroughly. Avoid using abrasive detergents, scourers, acidic cleaners such as lime scale remover, etc, as these could damage the enamel, and can result in development of rust and corrosion. If stains are particularly tough to remove, use cleaners specifically recommended to clean ovens and follow the instructions provided with the cleaner.

Never use a steam cleaner for cleaning inside the oven.

Do not clean using caustic creams, abrasive cleaning powders, thick wire wool or hard tools. Enameled parts of the oven can be damaged if excess cleaning liquids are not immediately removed.

After cleaning the interior parts of the oven with a soapy cloth, rinse it and then dry thoroughly with a soft cloth.

Clean the glass surfaces with special glass cleaning agents.

Never use flammable agents like acid, thinner or petrol when cleaning your oven.

Do not clean your oven with a steam cleaner.

Do not wash any part of your oven in a dishwasher.

Enameled Parts:

In order to keep enameled parts as new, it is necessary to clean them frequently with mild warm soapy water and then dry with a cloth. Do not wash them while hot and never use abrasive powders or abrasive cleaning materials. Do not leave anything spilled onto enameled parts for long periods of time.

Stainless Steel:

Stainless steel parts must be cleaned frequently with mildly warm soapy water and a soft sponge and then dried with a soft cloth. Do not use abrasive powders or abrasive cleaning materials. Do not leave anything spilled on stainless steel parts for long periods of time.

Replacing the oven lamps

Light source shall be replaced by professional.

WARNING: Ensure that the appliance is switched off before replacing the lamp to avoid the possibility of electric shock.

Remove the glass cover of the lamp-holder as shown below.

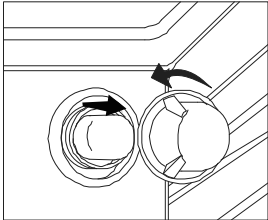

Remove the lamp and replace with a lamp resistant to high temperatures (300°C) with the following characteristics:

- Voltage: 220-240V
- Wattage: 25W
- Type: G9 (Halogen lamp)
- Energy efficiency class : G

Replace the glass cover and reconnect the oven to the mains power supply.

WARNING: Please do not use screwdrivers or other utensils to remove the light cover. This could damage the enamel of the oven or the lamp holder lamp holder.

PLEASE NOTE: The bulb replacement is not covered by your guarantee.

Removing the inner pane of Glass & Cleaning the Glass Door

1. Open door to a position you can view the screws on the edge of oven door. (See diagram eg Fig 1)
2. Using a screwdriver please remove the two screws as shown in the diagram (eg Fig 2)
3. Remove the bracket from the top of the oven door.
4. Now carefully remove the inner glass from the door.
5. Place the glass on a soft flat surface.
6. Clean the glass using non-abrasive products and sponges. Dry with a soft cloth.
7. Carefully place the glass back into the oven door frame.
8. Place the bracket back on the top of the glass and tighten the screws.



Fig 1



Fig 2

Care and maintenance

Looking after your appliance

Technical Specifications

Model : BITK63ESB / BITK63ESX

Voltage and Frequency : 220V-240V/ AC50Hz

Total Power : 1800-2200W

Oven usable Capacity : 69L

Energy Rating : A

We apologise for any inconvenience caused by minor inconsistencies within these instructions that may occur due to product improvements and development

All images and drawings are for illustration purposes only.

Energy fiche

Brand		
Model		BITK63ESB / BITK63ESX
Type of Oven		ELECTRIC
Mass	kg	28(+/-2)
Energy Efficiency Index - conventional		93
Energy Efficiency Index - fan forced		90
Energy Class		A
Energy consumption (electricity) - conventional	kWh/cycle	0.78
Energy consumption (electricity) - fan forced	kWh/cycle	0.76
Number of cavities		1
Heat Source		ELECTRIC
Volume	l	69
This oven complies with EN 60350-1		
Energy Saving Tips		
Oven		
- Cook the meals together, if possible.		
- Keep the pre-heating time short.		
- Do not elongate cooking time.		
- Do not forget to turn-off the oven at the end of cooking.		
- Do not open oven door during cooking period.		

Product support 6

Product support

Help is always at hand

Troubleshooting

PLEASE DO NOT attempt to repair this appliance yourself please contact the support contact centre on 01759 487823 or a qualified electrician.

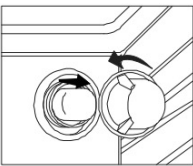
Problem	Possible Cause
The oven does not heat up.	<ul style="list-style-type: none"> * The oven may not be switched on; switch the oven on. * A household fuse may have blown or a circuit breaker may have tripped. If this happens continuously, call an authorised electrician.
A noise can be heard after a cooking programme.	<ul style="list-style-type: none"> * The cooling fan remains switched on after the end of a cooking program until the oven cools down.
The oven light / lamp is not working. 	<ul style="list-style-type: none"> * Disconnect the appliances from the electricity supply: Switch off and unplug at the socket, or switch the power off at the isolator as appropriate. * Turn the lamp anti-clockwise to release it and then pull it downwards to take it out. * Replace it with a new halogen light * Refit the lamp cover and turn it clockwise to secure it * Reconnect the appliance to the mains electricity supply
Cakes and biscuits are browning unevenly.	<ul style="list-style-type: none"> * There will always be a slight unevenness. If browning is very uneven, check that the correct temperature was set and that the correct shelf level was used.
Steam is coming from the oven.	<ul style="list-style-type: none"> * When cooking foods with a high-water content (e.g. oven chips) there may be some steam visible at the top of the door. * Take care when opening the oven door as there may be a momentary puff of steam when the door is opened. * Stand well back and allow any steam to disperse.
The knobs get hot when using the oven or the grill. Can this be avoided?	<ul style="list-style-type: none"> * Yes, this is caused by the heat rising from the oven or the grill and heating them up. * Do not leave the oven door open. * Make sure that the grill pan is pushed right back when grilling * Always grill with the compartment door closed.
Oven temperature is getting hotter as the cooker gets older.	<ul style="list-style-type: none"> * If turning the temperature down using the oven control knob has not worked, or has only worked for a short time, then you may need a new thermostat. * This should be fitted by a qualified service person
Grill is not cooking properly.	<ul style="list-style-type: none"> * Ensure you are using the pan and trivet supplied with the cooker * Ensure that the grill pan is placed in the upper part of the cavity; not on the base of the cavity * Ensure the grill pan is pushed all the way back
The oven is not cooking evenly.	<ul style="list-style-type: none"> * If you are cooking a large item, be prepared to turn it around during the cooking. * Ensure the shelves are in the correct positions.

Declaration of conformance to product standards

This appliance conforms to all relevant standards applicable to domestic appliances sold in the UK

Disposal



This appliance/fitting is marked according to the European directive 2012/19/EU on Waste Electrical and Electronic Equipment (WEEE).

By ensuring this product is disposed of correctly, you will help prevent potential negative consequences for the environment and human health, which could otherwise be caused by inappropriate waste handling of this product.

The symbol on the product, or on the documents accompanying the product, the **crossed out wheellie bin** symbol, indicates that this appliance/fitting may not be treated as household waste. Instead it shall be handed over to the applicable collection point for the recycling of electrical and electronic equipment.

Disposal must be carried out in accordance with local environmental regulations for waste disposal.

For more detailed information about treatment, recovery and recycling of this product, please contact your local authority, your household waste disposal service or the retailer where you purchased the product.



**Your Teknix appliances comes with a 2 year
parts and labour guarantee.**

Please REGISTER your appliance online at

www.teknixwarranty.co.uk



**You also have the option to EXTEND YOUR WARRANTY
to 5 years parts and labour.**

To register your appliance or extend your warranty

Please call 01759 48 78 23

We, Teknix, undertake that if within 24 months of the date of purchase this appliance or any part thereof is proven to be defective by reason of mechanical or electrical failure we will at our discretion repair or replace the same free of any charge for labour, materials or carriage on condition that:

- The appliance has been correctly installed in accordance to manufacturers' instructions.
- The appliance has been used for normal domestic purposes only and in accordance with our operating instructions.
- The appliance has not been repaired, taken apart or tampered with by any person not authorised by us.
- All repair work under this guarantee must be undertaken by the organisation or its authorised agents
- Proof of purchase is available on request
- If we decide your appliance cannot be repaired, or is uneconomical to repair, we'll replace it with the same model. If that model is no longer available, we'll discuss an alternative settlement with you.
- We reserve the right to charge for the expense of a service call if no fault has been found with the appliance after we have inspected it.
- All claims must be arranged via a call to us on 01759 487893. Without pre-authorisation it may result in the cost of claim not being reimbursed.

This guarantee is in addition to your statutory and other legal rights

Exclusions

- Damage resulting from transportation, improper use, or neglect.
- Appliance outside the United Kingdom.
- Consumer replaceable items including, but not limited to, batteries, light bulbs and other consumables.
- Cosmetic damage and/or non-functional parts, which do not affect the normal use of the product including for example cabinet, scratches and rust.
- Any loss suffered as a result of not being able to use the appliance or any loss other than the repair or the replacement cost of the product.
- Accidental or physical damage

